

**Multi Zone Amplifier  
Amplificateur Multizone**

# **XDA-QS5400RK**

**(XDA-QS5400 + Brackets)**

**(XDA-QS5400 + Supports)**

OWNER'S MANUAL

MODE D'EMPLOI

MANUAL DE INSTRUCCIONES

EN

FR

ES

# CONTENTS

## **BEFORE USING THE UNIT 3**

Accessories .....	3
About this manual .....	3

## **PART NAMES AND FUNCTIONS 4**

Front panel .....	4
Rear panel .....	5

## **PLACEMENT AND CONNECTION 6**

Placing the unit .....	6
Mounting the unit on a rack.....	6
Placing the unit without a rack .....	6
Connecting devices .....	7
Connecting speakers .....	8
Connecting speakers in bridge mode .....	8
Connecting to a wired network .....	8
Connecting external devices .....	8
Connecting the power cord .....	8

## **MusicCast 9**

What is MusicCast? .....	9
Installing MusicCast CONTROLLER .....	9
Adding the unit to the MusicCast network .....	9

## **SETTING THE UNIT 10**

Setting from a web browser .....	10
Web Setup screen.....	10
Confirming the IP Address of the unit.....	10
Displaying the Web Setup screen.....	11
Setting menu items .....	12

## **FIRMWARE UPDATING 15**

Updating the firmware with USB memory devices .....	15
---	----

## **INITIALIZING THE UNIT 15**

Restoring it to the factory preset settings .....	15
---	----

## **SPECIFICATIONS 16**

Specifications .....	16
Supported devices and file formats .....	18
Supported USB devices .....	18
Supported AirPlay devices.....	18
Supported file formats .....	18
Block diagram.....	18

## **TRADEMARKS 19**

# BEFORE USING THE UNIT

## Accessories

Confirm that all the following items are included in the package.

Front cover x 1

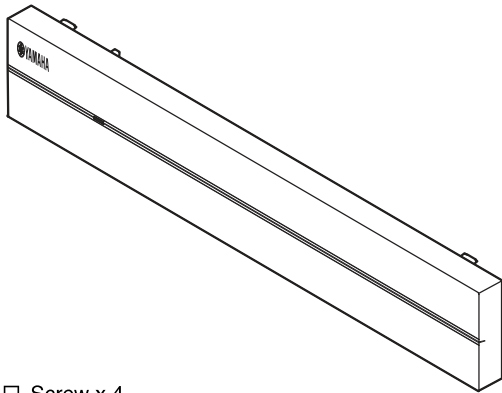

Euroblock plug x 4

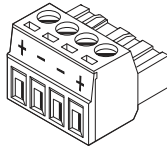

Bracket x 2

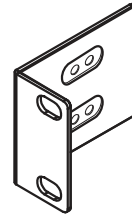

Screw x 4



Non-skid pad x 4

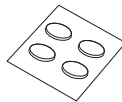

Power cord

Owner's Manual

Safety Brochure

### Note:

Screws for rack mounting are not included.

## About this manual

- This OWNER'S MANUAL explains preparations and operations for installers of the unit. Make sure to deliver this OWNER'S MANUAL to the user after the placement, connection and setup of the unit.
- Read the supplied booklet "Safety Brochure" before installing and using the unit.
- In this manual, iOS and Android mobile devices are collectively referred to as "mobile devices". The specific type of mobile device is noted in explanations as needed.
- Due to product improvements, specifications and appearance are subject to change without notice.
- Updates offering improved functionality of the dedicated "MusicCast CONTROLLER" app for mobile devices may become available without prior notice.

- The illustrations in this manual are for instructional purposes only.
- Access the Yamaha Downloads site to download the latest Owner's Manual and Safety Brochure.  
<http://download.yamaha.com/>

### Notice:

Indicates precautions for use to avoid the possibility of malfunction/damage to the unit.

### Note:

Indicates instructions and supplementary explanations for optimum use.

# PART NAMES AND FUNCTIONS

## Front panel

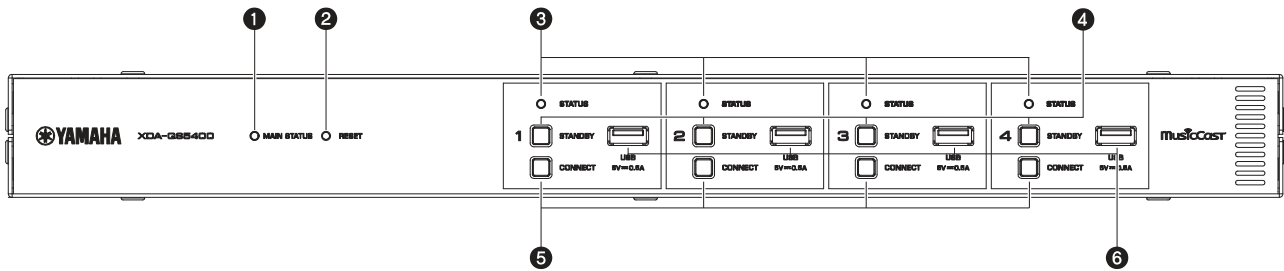

### 1 MAIN STATUS indicator

Indicates the unit status depending on its color and whether it is lit or flashing.

–	Unlit	Standby
White	Lit	Power on
Green	Flashing	Setting up the MusicCast connection
Dark red	Lit	Network Standby or ready for Cut / Fade function
Red	Lit or flashing	Error occurred

### Note

- When flashing green or red, the corresponding ZONE's STATUS indicator also flashes.
- The Cut / Fade function means that the audio signals that are input to CUT IN : IN (SENSING) jacks "cut in" or fade in the playback in each ZONE.

### 2 RESET key

Resets the unit. The unit is restarted forcibly by holding down RESET key for over 10 seconds.

### 3 STATUS indicators

Indicate the ZONE1 - ZONE4 status depending on whether they are lit or flashing.

–	Unlit	Standby
White	Lit	Power on
	Flashing	Setting volume or selecting input

### 4 STANDBY keys

Turn ZONE1 - ZONE4 to on / standby. The unit consumes a small power even in standby mode. The unit's standby power consumption depends on the standby configuration.

### 5 CONNECT keys

Add ZONE1 - ZONE4 to the MusicCast network using the MusicCast CONTROLLER app. The 4 ZONEs are independent of each other, so make sure to connect the mobile device with the MusicCast CONTROLLER app installed to the operating ZONE individually.

### 6 USB jacks

- Connection: USB Type-A
- File format system: FAT16, FAT32
- Voltage / current supply capacity: 5 V / 0.5 A

For connecting a USB storage device. You can play back music files stored on a USB storage device when you select "USB" as the input source.

# Rear panel

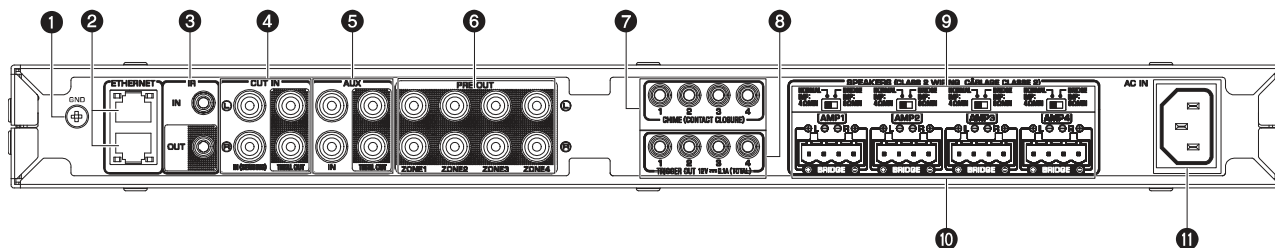

## 1 GND screw terminal

Connecting the source device chassis to the GND terminal of the unit may reduce noise in the signal.

### Note

The ground is not a safety ground.

## 2 ETHERNET jacks

Connection: RJ-45

For a wired connection to a network. Using an ETHERNET jack, connect the unit to your router with an Ethernet cable. Using another ETHERNET jack, you can connect the unit to another network device (such as another XDA-QS5400) in cascade.

### Notice

The unit is equipped with an Ethernet hub (Layer-2 Ethernet switch) internally. Do not connect both ETHERNET jacks to the same router. In that case, a routing loop might interfere with communication of the whole network.

## 3 IR IN/OUT jack

Connection: 3.5 mm monaural mini-plug

For connecting to an external remote control device and inputting/outputting remote control signals. The output with pass-through function is enabled even in standby mode.

## 4 CUT IN : IN (SENSING)/THRU. OUT jacks

Connection: stereo RCA plug (L/R)

**IN (SENSING):** For connecting to a paging system or another audio device. The audio signals cut in or fade in the playback in each ZONE.

**THRU. OUT:** For outputting analog audio signals input in IN (SENSING) jacks by pass-through function. The output is enabled even in standby mode.

## 5 AUX : IN/THRU. OUT jacks

Connection: stereo RCA plug (L/R)

**IN:** For connecting to an audio playback device such as a CD player (analog out jack) and inputting audio signals. You can play back music from an audio playback device when you select "AUX" as the input source.

**THRU. OUT:** For outputting analog audio signals input in AUX : IN jacks by pass-through function. The output is enabled even in standby mode.

## 6 PRE OUT/ZONE1-4 jacks

Connection: stereo RCA plug (L/R)

For connecting to external power amplifiers and outputting audio signals in ZONE1 - ZONE4.

## 7 CHIME (CONTACT CLOSURE) 1-4 jacks

Connection: 3.5 mm monaural mini-plug (Tip: + / Sleeve: -)

For connecting to contact closures such as door bells. When the contact closure is closed (+ and - of the jack is shorted), the preset chime sounds in the selected ZONE.

## 8 TRIGGER OUT 1-4 jacks

Connection: 3.5 mm monaural mini-plug (Tip: + / Sleeve: -)

For outputting trigger signals (DC 12 V). In general, the output level is "High" when the unit is powered on or "Low" in standby mode.

## 9 NORMAL/BRIDGE switch

Selects NORMAL/BRIDGE connection of speakers. This switch is normally set to NORMAL. Change the setting to BRIDGE only when the speaker is used in bridge connection.

### Note

Unplug the unit's power cord from the AC wall outlet before changing the NORMAL/BRIDGE switch setting.

## 10 SPEAKERS terminals

Connection: Euroblock connectors (supplied)

Speaker impedance: 4 Ω or over (NORMAL), 8 Ω or over (BRIDGE)

For connecting to speakers with supplied Euroblock connectors.

## 11 AC IN jack

For connecting the supplied power cord.

# PLACEMENT AND CONNECTION

## Placing the unit

### ■ Mounting the unit on a rack

Use the supplied brackets to mount the unit on an EIA standard rack. Screw the brackets to the unit horizontally.

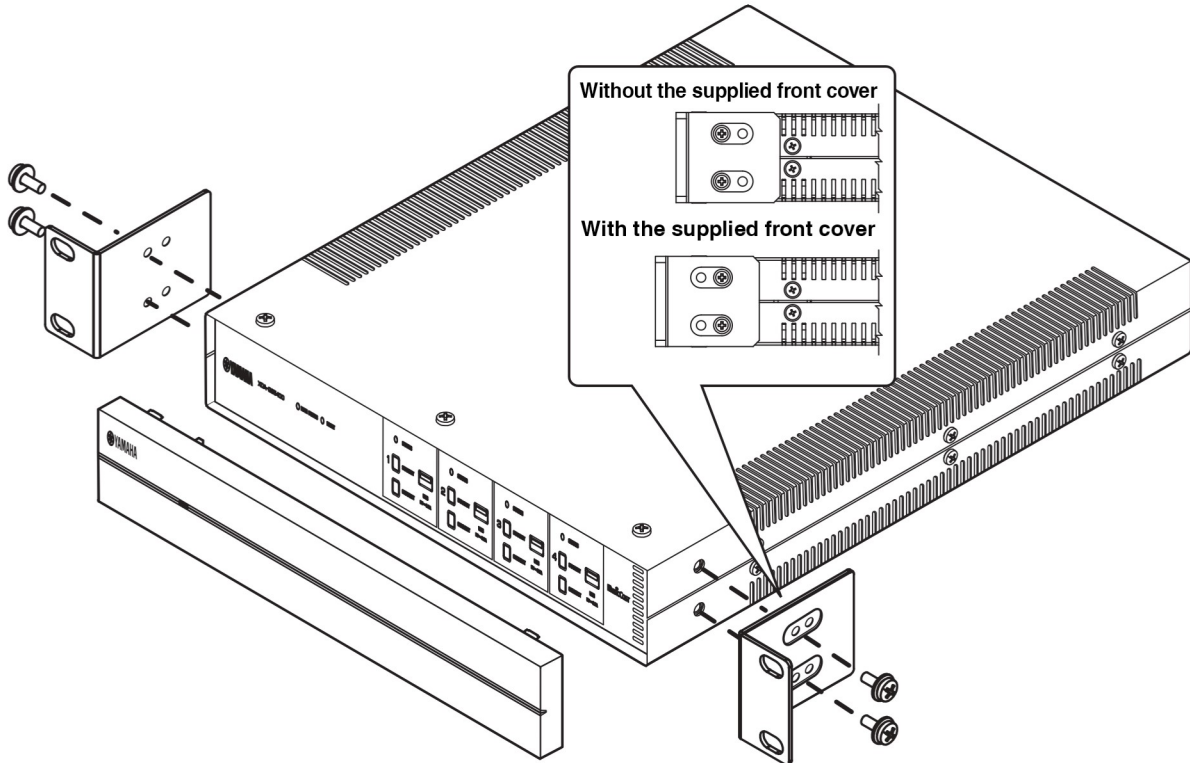

#### Notice

- Do not use the brackets for devices other than the XDA-QS5400.
- When installing brackets, use the included screws.
- Tighten the screws until the brackets are securely fixed.

#### Note

Screws for rack mounting are not included.

#### Precautions for rack mounting

If the unit is mounted together with additional units and/or other devices in an EIA standard equipment rack, the internal temperature can rise due to heat generated from the devices, resulting in impaired performance. If the unit is mounted in a rack, always observe the following requirements to avoid heat buildup:

- If the unit is mounted in a rack with other devices that generate a significant amount of heat, such as a power amplifier, leave more than 1U of space between the unit and other devices (both above and below). Also, make sure to either leave any open spaces uncovered or install appropriate ventilating panels to minimize the possibility of heat buildup.
- To ensure sufficient airflow, leave the rear of the rack open and position it at least 10 cm from walls or other surfaces.

### ■ Placing the unit without a rack

Affix the supplied non-skid pads at the four corners on the bottom of the unit, and then place the unit on a shelf or rack.

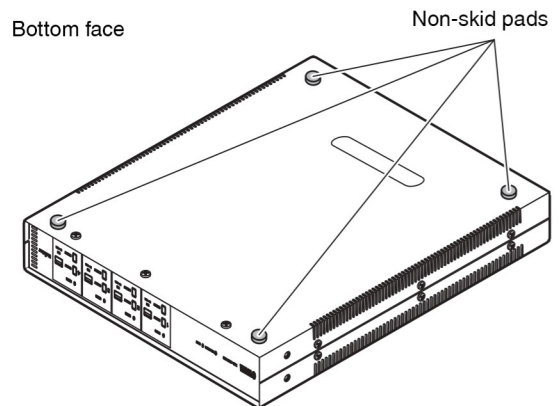

#### Note

Allow ventilation space of at least 10 cm (4 in.) on the top, either side and back of the unit.

# Connecting devices

The following is an example of connecting the devices. Unplug the unit's power cord from the AC wall outlet before connecting the devices.

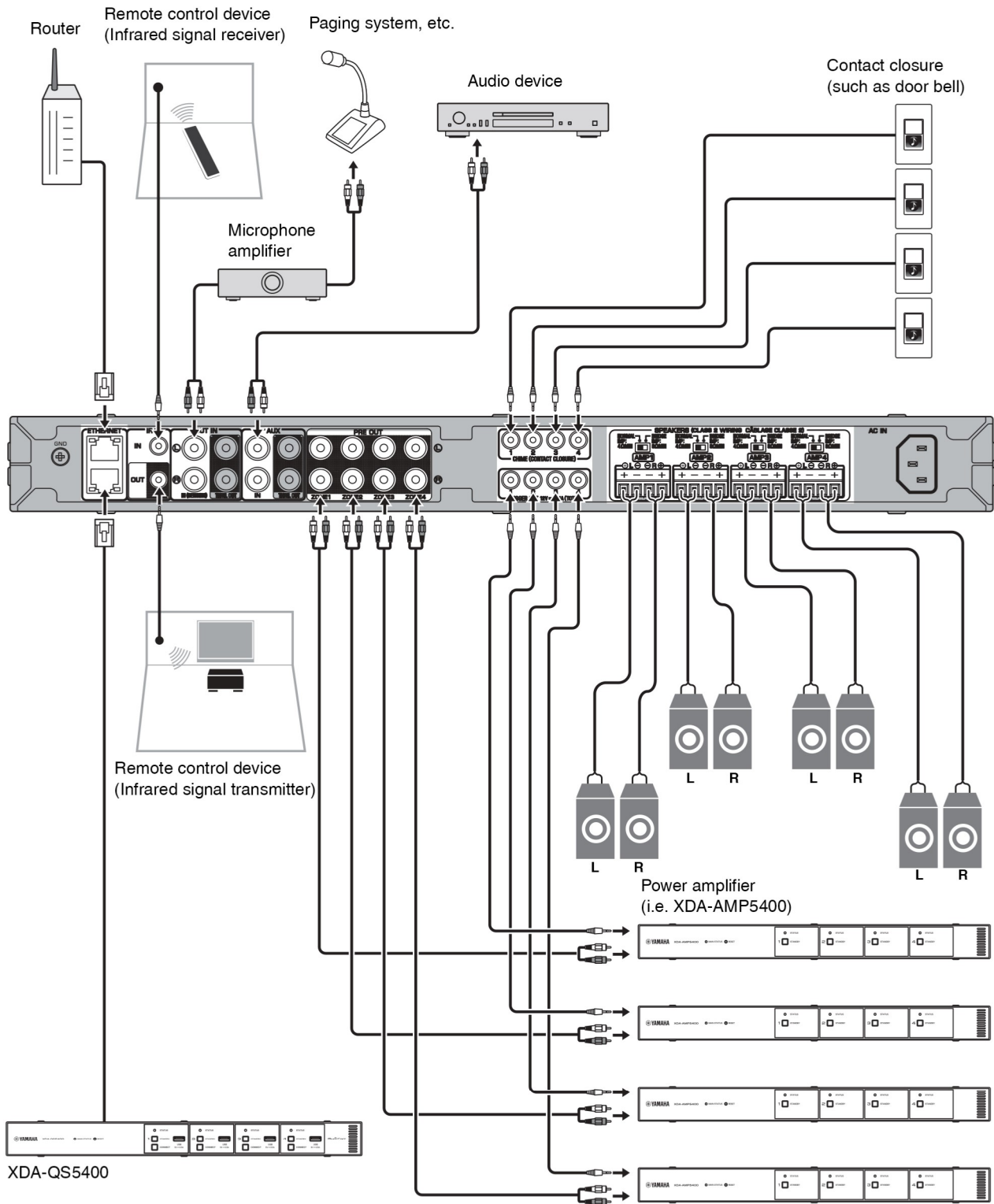

## ■ Connecting speakers

Connect the speakers to the unit with the supplied Euroblock plug and commercially-available speaker cables.

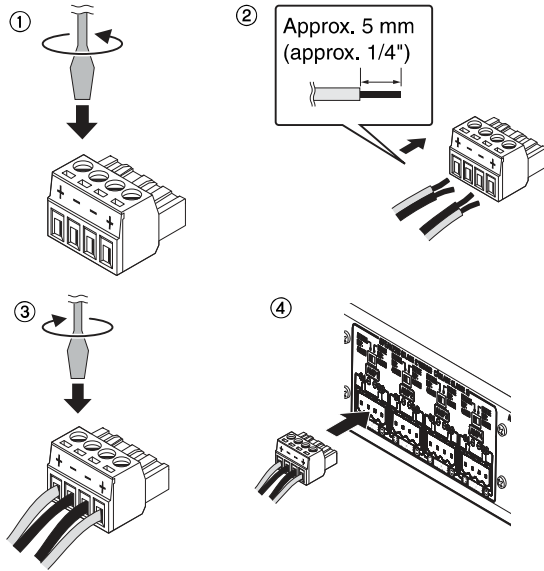

- 1 Loosen terminal screws.
- 2 Insert cables.
- 3 Securely tighten terminal screws.
- 4 Insert the Euroblock plug into the **SPEAKERS** terminals of the unit.

### Note

- You must use the supplied Euroblock plugs. If the plugs have been lost, please contact your Yamaha dealer.
- Recommended cable gauges for the Euroblock plug: AWG26 (0.13 mm<sup>2</sup>) to AWG16 (1.3 mm<sup>2</sup>)
- To prepare the cable for attachment to a Euroblock connector, strip the wire as shown in the illustration using stranded wire to make connections. With a Euroblock connection, stranded wires may be prone to breakage because of metal fatigue due to the weight of the cable or due to vibration. When rack mounting your device, use a lacing bar when possible to bundle and fasten the cables.
- Do not tin (solder) the exposed end.

## ■ Connecting speakers in bridge mode

Connect the speakers to the unit with the supplied Euroblock plug and commercially-available speaker cables, and set the NORMAL/BRIDGE switch to "BRIDGE".

### Note

Unplug the unit's power cord from the AC wall outlet before changing the NORMAL/BRIDGE switch setting.

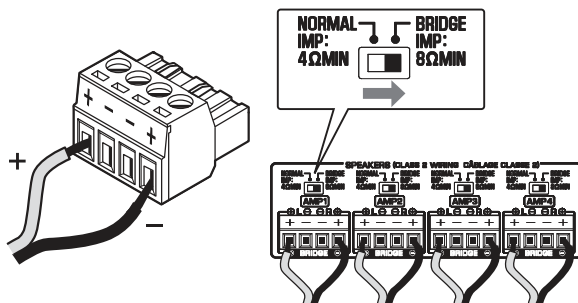

## ■ Connecting to a wired network

Connect the unit to your router with a commercially-available STP network cable (CAT-5 or higher straight cable).

Using another ETHERNET jack, you can connect the unit to another network device (such as another XDA-QS5400) in cascade.

### Note

Do not connect both ETHERNET jacks to the same router. In that case, a routing loop might interfere with communication of the whole network.

## ■ Connecting external devices

### ■ For a power amplifier

Use a commercially-available analog stereo pin cable (stereo audio RCA cable). You can connect a power amplifier to each ZONE.

### Note

To prevent loud sound or unexpected noise, before connecting a power amplifier, be sure to unplug the unit's power cord from the AC wall outlet and turn off the power amplifier.

### ■ For an external device with analog stereo audio output

Use a commercially-available analog stereo pin cable (stereo audio RCA cable).

### ■ For a paging system with the Cut/Fade function

Use a commercially-available analog stereo pin cable (stereo audio RCA cable). The audio signals from a paging system cut in or fade in the playback in each ZONE.

### Note

Control the Cut/Fade function using the Web Control screen. For details, see the following:

- "Setting menu items" (p.12)

### ■ For a contact closure (such as a door bell) with the ON/OFF switch

Use a commercially-available 3.5 mm monaural mini-plug cable. When the contact closure is closed, the preset chime sounds in the selected ZONE.

### Note

Control the chime function using the Web Control screen. For details, see the following:

- "Setting menu items" (p.12)

### ■ For a remote control device

Use a commercially-available 3.5 mm monaural mini-plug cable. For connecting to an infrared signal receiver/emitter that allows you to operate the unit and other devices from another room.

### ■ For a device compatible with the trigger function

Use a commercially-available 3.5 mm monaural mini-plug cable. The trigger function can control external devices (such as XDA-AMP5400) in conjunction with powering on/off the unit.

### Note

Control the trigger function using the Web Control screen. For details, see the following:

- "Setting menu items" (p.12)

## ■ Connecting the power cord

After all the connections are complete, plug the supplied power cord into the AC IN jack on the rear panel, and then plug the power cord to an AC wall outlet.

## What is MusicCast?

MusicCast allows you to share music among all of your rooms with a variety of Yamaha MusicCast compatible devices. Yamaha offers the free dedicated mobile app “MusicCast CONTROLLER”. This app allows the users of this unit to control the unit and other MusicCast compatible devices easily. Users can also enjoy music from their mobile device, media servers (PCs/NAS), and music streaming services. For more details and a lineup of MusicCast compatible products, refer to the following site:  
<http://www.yamaha.com/musiccast/>

### Note

Some streaming services may be asked to login from MusicCast CONTROLLER app.

## Installing MusicCast CONTROLLER



To use the network features on the MusicCast compatible device, you need the dedicated application “MusicCast CONTROLLER”. Search for the free application “MusicCast CONTROLLER” on the App Store or Google Play and install it to your device.

## Adding the unit to the MusicCast network

Perform the following procedure to add each ZONE to the MusicCast network.

### 1 Tap the “MusicCast CONTROLLER” application icon on your mobile device and tap “Setup”.

#### Note

If you want to add the the unit to the MusicCast network in the next ZONE, tap “Add New Device” in the “Settings”.

### 2 Operate the “MusicCast CONTROLLER” application following the on-screen instructions, and then hold down CONNECT on the front panel of the unit for 5 seconds.

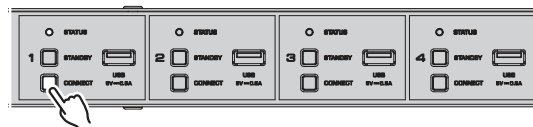

### 3 Operate the “MusicCast CONTROLLER” application following the onscreen instructions to set up the network.

This completes adding the unit to the MusicCast network.

# SETTING THE UNIT

## Setting from a web browser

### ■ Web Setup screen

You can modify the various unit settings with the Web Setup screen displayed in a web browser on your mobile device (such as a tablet) or PC.

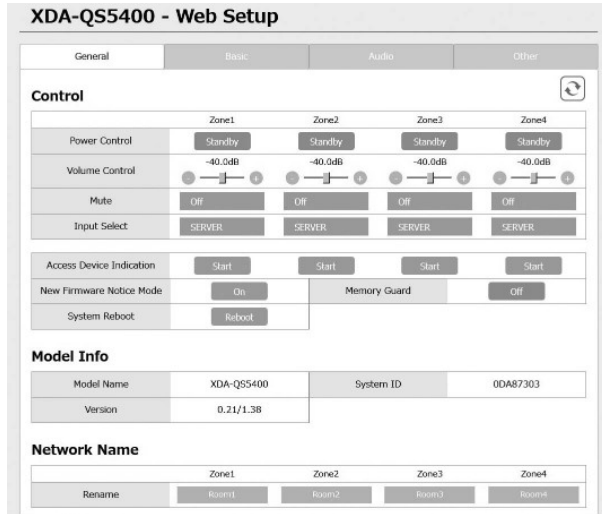

The Web Setup screen appears when you type the IP address of the unit followed by "/Setup" into the address field of a web browser. You can configure the various settings in ZONE1 to ZONE4 all together.

### ■ Confirming the IP Address of the unit

Follow the procedure below to confirm the IP Address of the unit after setting up MusicCast.

#### 1 Hold down the room name (or the unit name) on the MusicCast CONTROLLER screen.

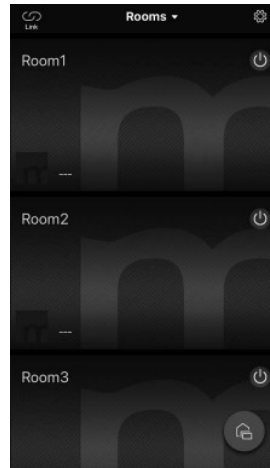

#### 2 Tap "Room Settings".

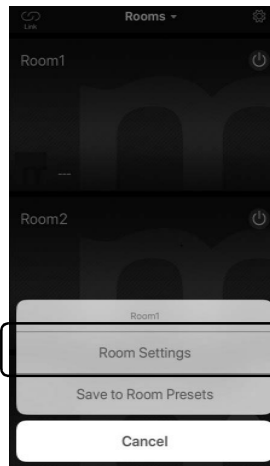

### 3 Tap “Information”, and check the IP Address of the unit.

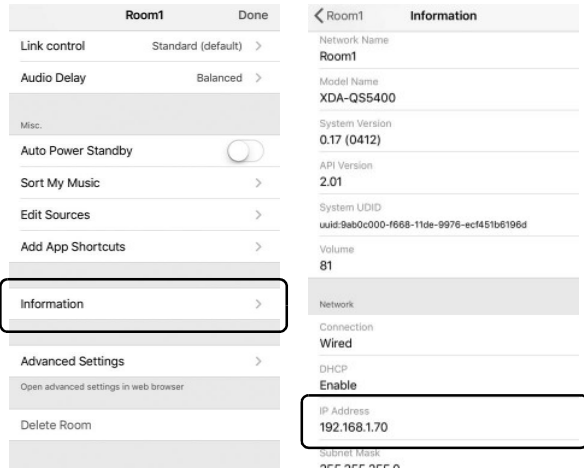

### ■ Displaying the Web Setup screen

Using the IP Address of the unit, you can display the Web Setup screen.

Type the IP Address of the unit followed by “/Setup” into the address field of a web browser on your mobile device (such as a tablet) or PC, and press ENTER. The Web Setup screen for the unit appears.

For example:

<http://192.168.1.70/Setup>

#### Note

Be sure not to type only the IP address of the unit into the address field of a web browser. The Web Setup screen does not appear without “/Setup”.

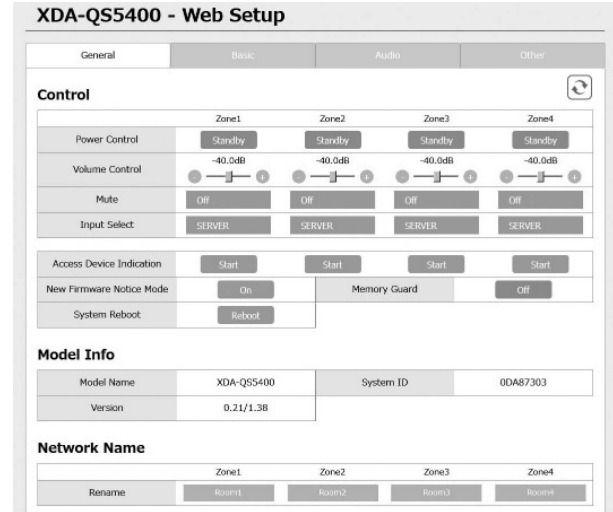

## Setting menu items

The following items can be displayed and configured on the Web Setup Screen.

Tab	Menu	Item	Setting values	Default	Explanation		
General	Control	Power Control	Standby / On	Standby	Turns on/off (standby) each Zone. "Off" could include Network Standby		
		Volume Control	Mute / -80.0 to 0.0dB (0.5dB Steps)	-40.0dB	Adjusts the volume in each Zone.		
		Mute	Off / Att -20 dB / Att -40 dB /On	Off	Mutes the audio output in each Zone.		
		Input Select	(streaming services) / AirPlay / MusicCast Link / SERVER / NET RADIO / USB / AUX	SERVER	Sets an input source in each Zone.		
		Access Device Indication	-	-	Flashes the STATUS indicator of the device (ZONE) currently being used for operation via a web browser.		
		New Firmware Notice Mode	Off / On	On	Enables/disables a mode that gives notification of new firmware on the MusicCast CONTROLLER screen.		
		Memory Guard	Off / On	Off	Protects the settings of the unit and prevents them from being modified.		
		System Reboot	-	-	Restarts the entire system.		
		Model Info		Model Name	-	-	Displays the model name of the unit.
				System ID	-	-	Displays the system ID of the unit.
Version	-			-	Displays the version of firmware currently installed on the unit.		
Network Name	Rename	-	-	Edits the network name (the Zone's name on the network) displayed on other network devices.			
Network Info		IP Address	-	-	Displays the IP address for each Zone.		
		Subnet Mask	-	-	Displays the subnet mask for each Zone.		
		Default Gateway	-	-	Displays the IP address of the default gateway for each Zone.		
		DNS Server (P)	-	-	Displays the IP address of the primary DNS server.		
		DNS Server (S)	-	-	Displays the IP address of the secondary DNS server.		
		MAC Address	-	-	Displays the MAC address for each Zone.		
Network Settings		DHCP	Off / On	On	Enables/disables the DHCP function.		
		IP Address	-	-	Sets the IP address for each Zone.		
		Subnet Mask	-	-	Sets the subnet mask for each Zone.		
		Default Gateway	-	-	Sets the IP address of the default gateway for each Zone.		
		DNS Server (P)	-	-	Sets the IP address of the primary DNS server.		
		DNS Server (S)	-	-	Sets the IP address of the secondary DNS server.		

Tab	Menu	Item	Setting values	Default	Explanation
Basic	Settings	Output Select AMP1 (2/3/4)	Zone1 / Zone2 / Zone3 / Zone4 / None	AMP1 - Zone1, AMP2 - Zone2, AMP3 - Zone3, AMP4 - Zone4	Sets the zone as the audio output in each channel.
		BTL1 (2/3/4)	-	-	Displays normal/bridge connection of speakers.
		AMP/BTL Trim	-10.0 to +10.0dB (0.5dB Steps)	0.0dB	Corrects volume difference between each channel and the standard output signal.
		Preout Trim	-10.0 to +10.0dB (0.5dB Steps)	0.0dB	Corrects volume difference between each preout signal in each Zone.
		Input Trim	-6.0 to +6.0dB (0.5dB Steps)	0.0dB	Compensates for volume differences between input sources.
		Auto Power Standby	Off / 5 min / 20 min / 2 Hr / 4 Hr / 8 Hr / 12 Hr	U.K. and Europe models : 20 min Other models : Off	Automatically sets the unit to standby mode when there are no operations for a specified amount of time. When this is set to 5 min or 20 min, the unit will only be set to standby mode automatically if there is no input signal during the 5 or 20 minutes without any operations.
		Network Standby	Off / On / Auto	Auto	Enables/disables the feature allowing the Zone to be turned on by network devices (Network Standby). When this is "Auto", Network power will turn off when the main power is off and the unit continues not to be linked to network devices.
		Chime1 (2/3/4)	Off / On	Off	Enables/disables the feature allowing the preset chime to sound in each Zone when the + and - of the CHIME 1 (/2/3/4) jack are shorted.
					<b>Note</b> If this function is enabled, the unit's standby power consumption increases to output audio immediately.
		Chime Volume	Mute, -80.0 to 0.0dB (0.5dB Steps)	-30.0dB	Adjusts the chime volume in each Zone.
		Chime1 (2/3/4) Sound	(Sounds)	-	Sets the preset chime for the CHIME 1 (/2/3/4).
		Chime1 (2/3/4) Test	-	-	Tests the preset chime sound for the CHIME 1 (/2/3/4).
		CUT IN	Off / On	Off	Enables/disables the Cut in/Fade function in each Zone.
		CUT IN Power On	Disable / Enable	Disable	Enables/disables the feature allowing the Zone to be turned on by the CUT IN input in each zone.
					<b>Note</b> If all Zones are turned off (standby) and this function is enabled, the unit's power consumption increases to output audio immediately.
		CUT IN Mode	Fade / Cut - 5sec / Cut - 10sec / Cut - 30sec / Cut - 1min / Cut - 5min	Fade	Sets whether the audio signals from the CUT IN jacks fade in or cut in the playback. "Fade": mixes the audio signals from the CUT IN jacks into the lowered playback. The unit will be set to the previous playback automatically if there is no CUT IN signal for 3 seconds. "Cut": mutes the playback and outputs the audio signals from the CUT IN jacks instead. The unit will be set to the previous playback automatically if there is no CUT IN signal for 5 seconds to 5 minutes.
CUT IN Trim	-30.0 to +30.0dB (0.5dB Steps)	0.0dB	Adjust the volume difference between the CUT IN input and the standard output signal.		
			<b>Note</b> If this is set to a high level, the sound may become clipped when the master volume level is high. It is recommended to set CUT IN Trim to a level at which there is no clipping at the desired master volume levels.		
CUT IN Input Sense	Low / Mid / High	Mid	Sets the sensitivity for audio input signal level of the CUT IN jacks. "Low": lowers the sensitivity and reacts to only loud sound. "High": heightens the sensitivity and reacts to even small sound.		

Tab	Menu	Item	Setting values	Default	Explanation
		Trigger Out	Power sync / Manual	Power sync	Specifies the condition for the TRIGGER OUT jack to function. "Power sync": functions in sync with the power status (On/Off). "Manual": manually switches the output level (High/Low) for electronic signal transmission.
		Manual Control	Hi / Lo	Hi	Sets the output level (High/Low) for the TRIGGER OUT jack.
		AirPlay Volume Interlock	Off / Limited / Full	Limited	Sets whether or not the volume of the Zone and the volume of iTunes or the iPhone are synchronized when AirPlay input is selected.
Audio	Settings	Equalizer Mode	Bypass / Auto / Manual	Auto	Adjusts the volumes for the low-frequency, middle-frequency, and high-frequency ranges of the audio. When this is "Auto", they stay synchronized with the volume and perform hearing correction for the auditory response of the human ear.
		Equalizer Manual : High	-6.0 to +6.0dB (0.5dB Steps)	0.0dB	Adjusts the volume of the high-frequency range of the audio output.
		Equalizer Manual : Mid	-6.0 to +6.0dB (0.5dB Steps)	0.0dB	Adjusts the volume of the middle-frequency range of the audio output.
		Equalizer Manual : Low	-6.0 to +6.0dB (0.5dB Steps)	0.0dB	Adjusts the volume of the low-frequency range of the audio output.
		Enhancer	Off / On	On	Enables/disables the Compressed Music Enhancer feature.
		Bass Extension	Off / On	Off	Enables/disables enhanced bass sound, regardless of the size of the speakers.
		Monaural Downmix	Off / On	Off	Enables/disables a mode that plays back stereo signals downmixed to monaural audio.
		Speaker Type	Compact / Bookshelf / Floor standing / In-ceiling / In-wall	Bookshelf	Adjusts the effects of features such as Bass Extension for optimal results depending on the speaker type. "Compact": optimizes for small speakers. "Bookshelf": optimizes for bookshelf speakers. "Floor standing": optimizes for large speakers that are placed on the floor. "In-ceiling": optimizes for speakers embedded in the ceiling. "In-wall": optimizes for speakers embedded in walls.
		Initial Volume Mode	Off / On	Off	Enables/disables setting of the initial volume when each Zone is turned on.
		Initial Volume	Mute / -80.0 to 0.0dB (0.5dB Steps)	-40.0dB	Sets the initial volume for when each Zone is turned on.
		Max Volume	-60.0 to 0.0dB (0.5dB Steps)	0.0dB	Sets an upper limit for the volume levels to which each Zone can be adjusted.
		Auto Play	Off / On / Auto	different for every input source	Sets whether or not audio is automatically played back from servers, USB devices, etc. when each Zone is turned on or the input source is switched. "Off": always starts up with playback stopped. "On": starts automatically to play back the last content which you played back. "Auto": starts automatically to play back the last content only if it was being played back when the Zone was set to standby mode.
<b>Note</b>					
The setting value is different for every input source or service.					
Others	Factory Preset	Factory Preset	-	-	Initializes to factory preset settings.
	Web Settings Link	AirPlay Password	-	-	Sets the Zone's password for AirPlay.
		Backup / Restore	-	-	Saves the Zone's current settings to a PC or restores them from a backup on a PC.

## FIRMWARE UPDATING

### Updating the firmware with USB memory devices

---

You can update the firmware using USB memory devices. Download the firmware update file from the Yamaha website to a PC, and copy it to 4 USB memory devices in advance.

#### Note

- Each ZONE needs the firmware update.
- Use 4 USB memory devices to update the firmware of the 4 Zones at once.

**1 Turn each ZONE to standby and disconnect the power cord from the AC wall outlet.**

**2 Connect the USB memory devices to the USB jacks of ZONE1 to ZONE4 on the front panel.**

**3 While holding down CONNECT1 and CONNECT3 on the front panel, plug the power cord into the AC wall outlet.**

The firmware update starts. The STATUS indicator of each ZONE flashes during the update and the MAIN STATUS indicator lights up in sky blue.

**4 When the update is finished, press STANDBY1 to reset all of the ZONES.**

When updating is finished, the STATUS indicator on each ZONE is turned off and the MAIN STATUS indicator lights up in white.

## INITIALIZING THE UNIT

### Restoring it to the factory preset settings

---

To initialize the unit, select "Factory Preset" from the "Web setup" screen, or set all Zones to standby and then hold down the CONNECT1 and CONNECT2 keys simultaneously for 5 seconds or longer. When it becomes initialized, the power of ZONE1 will also turn on.

# SPECIFICATIONS

## Specifications

The specifications of the unit are as follows.

### Input jacks

Analog Audio

- Stereo Audio (RCA) x 2 (CUT IN, AUX)

### Output jacks

Analog Audio

- Speaker Out x 4 (L/R)
- Stereo Audio (RCA) x 4 (PRE OUT)
- Stereo Audio (RCA) x 2 (CUT IN, AUX)

### Other jacks

- USB x 4 (USB2.0)
- Network (Wired) x 2 (Internal speed: 100Base-TX/10Base-T, External speed: 1000Base-T/100Base-TX/10Base-T)
- Trigger Out x 4
- Remote In x 1
- Remote Out x 1
- Chime x 4

### USB

Device Capability: Mass Storage Class USB Memory  
Current Supply Capacity: 0.5 A

### Network

PC Client Function  
AirPlay supported  
Internet Radio  
Streaming Service

### Audio Section

Rated Output Power

- (2-channel driven, 1 kHz, 0.9% THD, NORMAL, 4/8 Ω) 90/50 W
- (2-channel driven, 1 kHz, 0.9% THD, BRIDGE, 8 Ω) 100 W
- (1-channel driven, 1 kHz, 0.9% THD, NORMAL, 4/8 Ω) 100/50 W
- (1-channel driven, 1 kHz, 0.9% THD, BRIDGE, 8 Ω) 200 W

Dynamic Power

- (2-channel driven, 20 Hz to 20 kHz, 0.08% THD, 20ms Burst, NORMAL, 4/8 Ω) 80/40 W
- (2-channel driven, 20 Hz to 20 kHz, 0.08% THD, 20ms Burst, BRIDGE, 8 Ω) 150 W
- (2-channel driven, 1 kHz, 0.9% THD, 20ms Burst, NORMAL, 4/8 Ω) 100/50 W
- (2-channel driven, 1 kHz, 0.9% THD, 20ms Burst, BRIDGE, 8 Ω) 200 W
- (All channel driven, 1 kHz, 0.9% THD, 20ms Burst, NORMAL(8-ch), 4/8 Ω) 80/50 W
- (All channel driven, 1 kHz, 0.9% THD, 20ms Burst, BRIDGE(4-ch), 8 Ω) 170 W

Maximum Effective Output Power (JEITA)

- (1-channel driven, 1 kHz, 10% THD, NORMAL, 4/8 Ω) 130/65 W
- (1-channel driven, 1 kHz, 10% THD, BRIDGE, 8 Ω) 260 W

Total Harmonic Distortion (THD)

- (20 Hz to 20 kHz, SP OUT, 25 W, 8 Ω) 0.04% THD
- (20 Hz to 20 kHz, PRE OUT, 1 V) 0.005% THD

Frequency Response (+0/-3 dB)

- PRE OUT (NET/USB IN) 10 Hz to 22 kHz
- PRE OUT (AUX IN) 10 Hz to 22 kHz
- SP OUT (NET/USB IN) 10 Hz to 22 kHz
- SP OUT (AUX IN) 10 Hz to 22 kHz

Signal to Noise Ratio (IHF-A)

- PRE OUT (NET/USB IN) 114 dB
- PRE OUT (AUX IN) 108 dB
- SP OUT (NET/USB IN) 106 dB
- SP OUT (AUX IN) 104 dB

Rated Output Level / Output Impedance

- PRE OUT (L/R, 1 kHz) 2.0 V/470 Ω

Maximum Output Level

- PRE OUT (L/R, 0.9% THD) 4.0 V

Gain

- SP OUT (1 V INPUT) 25.8 dB

Input Sensitivity

- 1 W power (1 W/8 Ω output) 150 mV
- MAX power (50 W/8 Ω output) 1.0 V

Volume Control

- PRE OUT/SP OUT Mute, -80 dB to 0.0 dB (0.5 dB Step)

EQ Characteristics

- Bass Variable width -6.0 dB to +6.0 dB (0.5 dB Step)
- Bass Turnover Frequency 350 Hz
- Mid Variable width -6.0 dB to +6.0 dB (0.5 dB Step)
- Mid Center Frequency 1.1 kHz
- Treble Variable width -6.0 dB to +6.0 dB (0.5 dB Step)
- Treble Turnover Frequency 3.5 kHz

Maximum Input Signal

- AUX IN (1 kHz, 0.9% THD) 2.4 V

### General

Power Supply

- [U.S.A. model] AC 120 V, 60 Hz
- [Other models] AC 220 to 240 V, 50/60 Hz

Power Consumption

- All Zone On, No Signal Condition 130 W
- All Zone Off, Chime On 40 W
- All Zone Off, CUT IN On, CUT IN Power On Enable 18.2 W
- All Zone Off, CUT IN On, CUT IN Power On Enable 18.2 W

Standby Power Consumption

- Network Standby Off 0.2 W
- Network Standby On (1 Zone) 3.2 W
- Network Standby On (4 Zones) 6.0 W

Dimensions (W x H x D)

437 x 46 x 443 mm (17-1/4" x 1-3/4" x 17-3/8")

Weight

6.3 kg (13.9 lbs)

Reference Dimensions

- Brackets with front cover

481 x 44 x 453 mm (18-7/8" x 1-3/4" x 17-7/8")

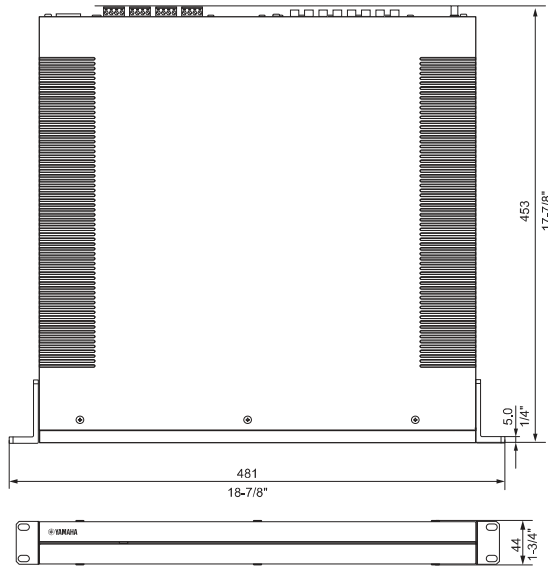

- Table Top Mount-with front cover

437 x 46 x 453 mm (17-1/4" x 1-3/4" x 17-7/8")

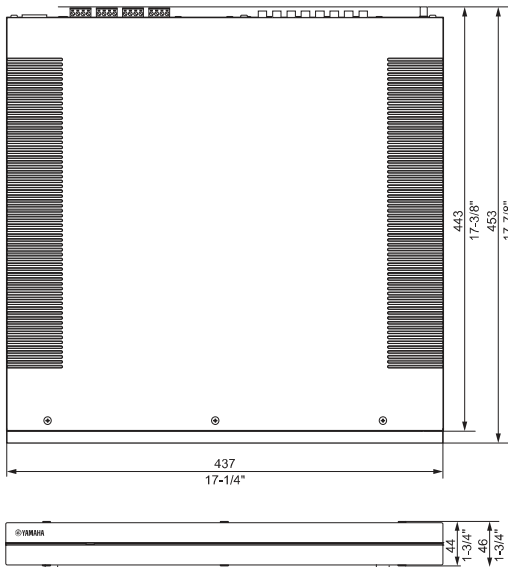

- Brackets

481 x 44 x 443 mm (18-7/8" x 1-3/4" x 17-3/8")

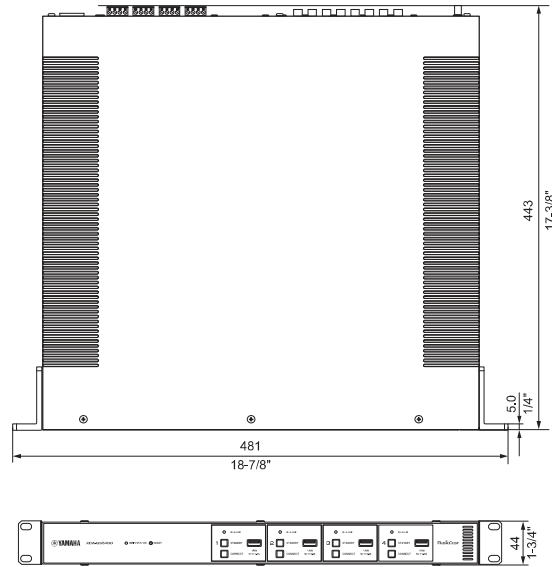

\* The contents of this manual apply to the latest specifications as of the publishing date. To obtain the latest manual, access the Yamaha website then download the manual file.

# Supported devices and file formats

## ■ Supported USB devices

The following USB devices can be used by the unit.

- The unit is compatible with USB memory devices that are in FAT16 or FAT32 format. Do not connect any other type of USB devices.
- USB devices with encryption cannot be used.
- Operation of all USB devices cannot be guaranteed.

## ■ Supported AirPlay devices

Made for (as of September 2018):

iPhone X, iPhone 8 Plus, iPhone 8, iPhone 7 Plus, iPhone 7, iPhone SE, iPhone 6s Plus, iPhone 6s, iPhone 6 Plus, iPhone 6, iPhone 5s, iPhone 5c, iPhone 5, iPhone 4s  
 iPad Pro (10.5"), iPad Pro (12.9") 2nd Generation, iPad Pro (12.9") 1st Generation, iPad Pro (9.7"), iPad mini 4, iPad Air 2, iPad mini 3, iPad Air, iPad mini 2, iPad mini, iPad (6th generation), iPad (5th generation), iPad (4th generation), iPad (3rd generation), iPad 2  
 iPod touch (6th generation), iPod touch (5th generation)

## ■ Supported file formats

The following file formats can be used by the unit.

File	Sampling frequency (kHz)	Quantization bits (bit)	Bitrate (kbps)	Number of channels	Support for gapless playback
WAV *	32/44.1/48/88.2/96/176.4/192	16/24/32	-	2	✓
MP3	32/44.1/48	-	8 to 320	2	-
WMA	32/44.1/48	-	8 to 320	2	-
MPEG-4 AAC	32/44.1/48	-	8 to 320	2	-
FLAC	32/44.1/48/88.2/96/176.4/192	16/24	-	2	✓
ALAC	32/44.1/48/88.2/96	16/24	-	2	✓
AIFF	32/44.1/48/88.2/96/176.4/192	16/24/32	-	2	✓

\* Linear PCM format only. 32 bit-float files cannot be played back.

- The playable file formats differ depending on the software installed on media servers (PCs/NAS). Refer to the instruction manual of the server software for details.
- Digital Rights Management (DRM) content cannot be played back.

## ■ Block diagram

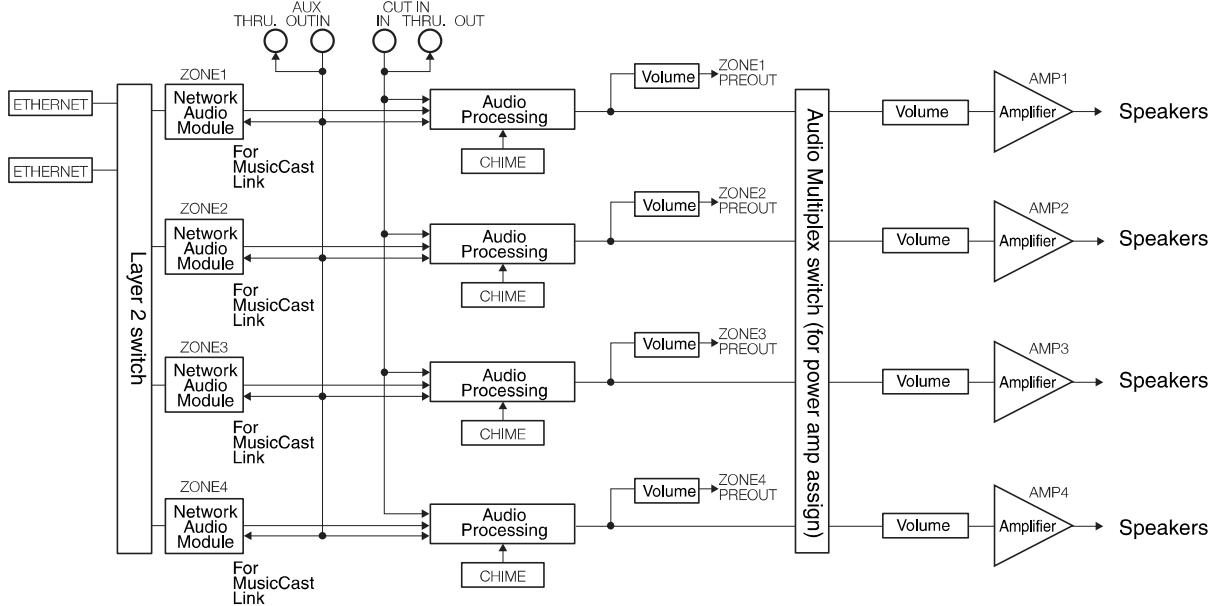

# TRADEMARKS



Use of the Works with Apple badge means that an accessory has been designed to work specifically with the technology identified in the badge and has been certified by the developer to meet Apple performance standards.

Apple, iPad, iPad Air, iPad Pro, and iPhone are trademarks of Apple Inc., registered in the U.S. and other countries. App Store is a service mark of Apple Inc.

## **Android™**

## **Google Play™**

Android and Google Play are trademarks of Google LLC.



MusicCast is a trademark or registered trademark of Yamaha Corporation.

## **Explanations regarding GPL**

This product utilizes GPL/LGPL open-source software in some sections. You have the right to obtain, duplicate, modify, and redistribute this open-source code only. For information on GPL/LGPL open source software, how to obtain it, and the GPL/LGPL license, refer to the Yamaha Corporation website. <http://download.yamaha.com/sourcecodes/musiccast/>

## **Licenses**

For information on the licenses of the third-party software in this product, refer to the following.

[http://\(IP address of this product\\*\)/licenses.html](http://(IP address of this product*)/licenses.html)

\* IP address of this product can be found with MusicCast CONTROLLER.