

# ADAPTIVE PRO 96W

## 5-in-1 Dimmable 24V Power Supply

The Adaptive Pro 5-in-1 dimmable Class 2 drivers are designed to operate with any standard MLV / ELV / Incandescent TRIAC (forward phase) dimmer switch or can also be used with secondary side controls systems. Encased in a low profile aluminum enclosure that includes knock-outs for easy installation in any low voltage application.

- Slim and compact 24V DC constant voltage hardwire driver
- Dedicated line voltage and low voltage wiring compartments
- Multiple 7/8" knock-outs for easy wire configuration
- Short circuit, over-voltage, over-temperature, overload protections
- 5-in-1 Forward and Reverse Phase Dimming:  
ELV / MLV / TRIAC / 0-10V/ 1-10V/Potentiometer / 10V PWM 4-in-1
- cULus Listed Wet location rated
- Class 2, Type HL, FCC Compliant



PROJECT:
TYPE:
LOCATION:
CATALOG NUMBER:



### ADAPTIVE PRO - 96W QUICK SPECS

SERIES	ADPTPRO-DRJ 96W
INPUT VOLTAGE	100-277V AC
INPUT FREQUENCY	47-63Hz
OUTPUT VOLTAGE	24V DC
RATED CURRENT	4A
POWER FACTOR	0.98@120V / 0.95@277V
MIN LOAD	9.6W
MAX LOAD	96W
EFFICIENCY	> 83% (120V) / 86% (277V)
DIMENSIONS	8.70" (221mm) L x 3.77" (96mm) W x 1.73" (44mm) H
DIMMING	0-100%
STORAGE TEMP	-40°F to 176°F (-40°C to 80°C)
AMBIENT TEMP	-40°F to 140°F (-40°C to 60°C)
OPERATING TEMP	-40°F to 140°F (-40°C to 60°C)
RATING	cULus Listed for Wet locations

### ADAPTIVE PRO - 96W QUICK DIMENSIONS

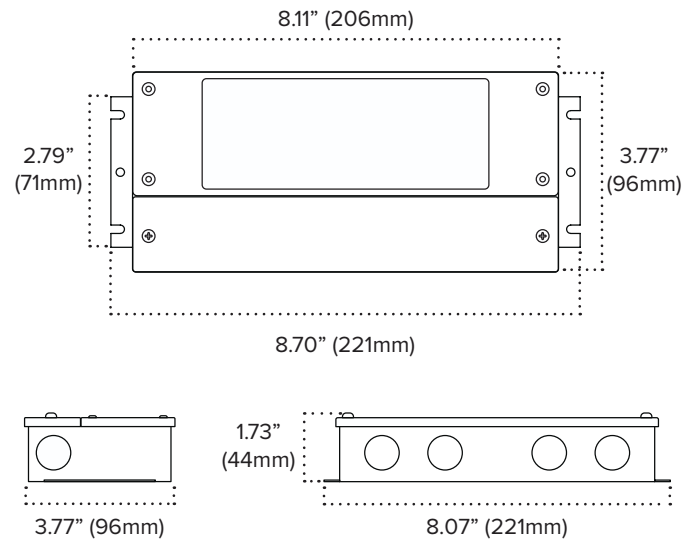

### ADAPTIVE PRO - 96W ORDERING INFORMATION

ITEM NUMBER	DESCRIPTION
PLX-ADPTDRJ24V-96	Adaptive Pro 24V - 96W Power Supply

### ADAPTIVE PRO - 96W QUICK SET UP

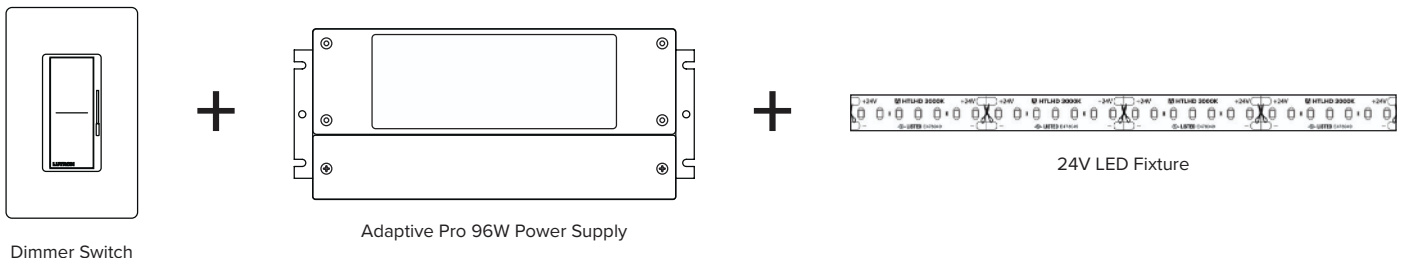

**ADAPTIVE PRO - 96W TRIAC/ELV/MLV DIMMING WIRING DIAGRAM**

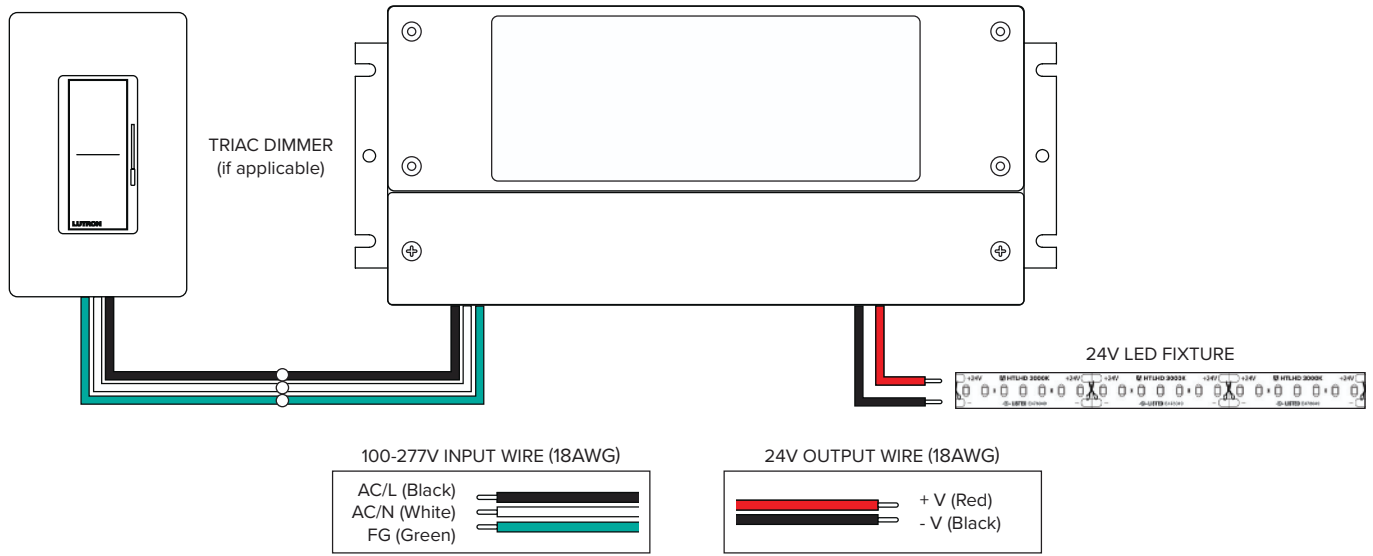

**ADAPTIVE PRO - 96W 0-10V WIRING DIAGRAM**

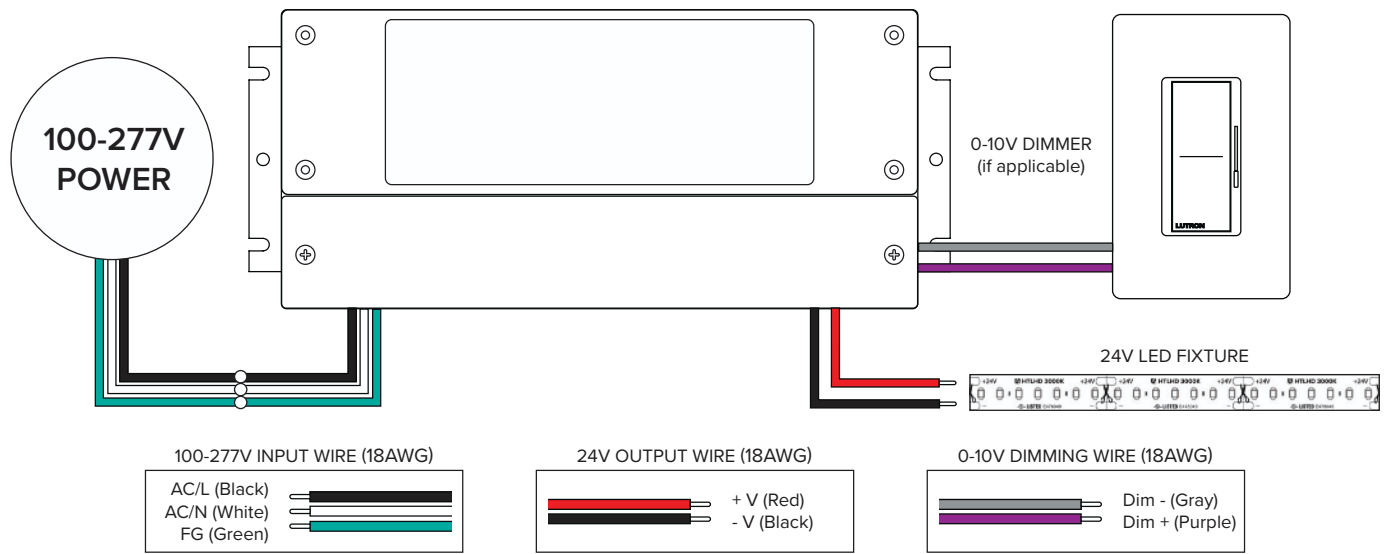

**LOAD**

0-100% LOAD	UP TO 40°C (104°F)
80% LOAD	UP TO 50°C (122°F)
60% LOAD	UP TO 60°C (140°F)
0% LOAD	STORAGE ONLY UP TO 80°C (176°F)

**ENVIRONMENT**

SERIES	ADPTPRO-DRJ 96W
WORKING TEMPERATURE	-40°C~+60°C. (See Derating Curve)
WORKING HUMIDITY	20~90%RH, Non-condensing
STORAGE TEMPERATURE HUMIDITY	-40°C~+80°C, -40°C~+80°C, 10~95%RH

**DERATING CURVE**

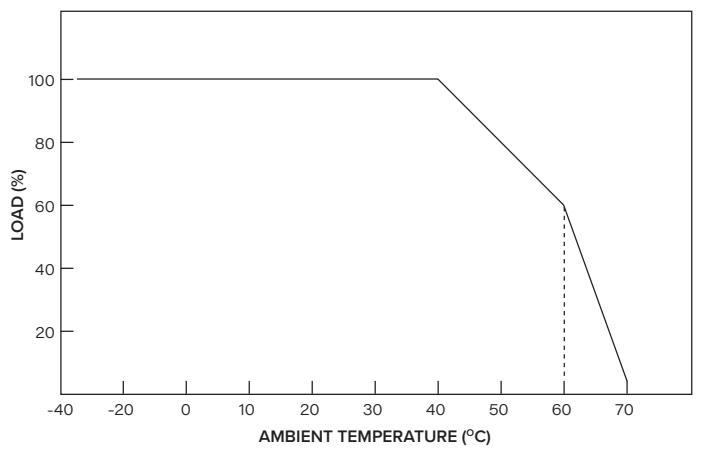



# PROLUXE LIGHTING WARRANTY

## LIMITED WARRANTY FOR LED PRODUCTS: 2 YEARS

### LIMITED PRODUCT WARRANTY

Our products are warranted to be free from defects in material and workmanship for the warranty period listed. Warranty periods begin from the date of shipment from American Lighting Inc's warehouse to the original purchaser. Products that prove to be defective during their specific warranty period will be either repaired or replaced, at the sole discretion of American Lighting Inc. Claims for defective products must be submitted in writing to American Lighting Inc's RGA Department within the warranty period. Upon approval of such return, American Lighting Inc reserves the right to inspect the product for misuse or abuse. Claims for indirect or consequential damages or for product that, in American Lighting Inc's opinion, has been misused will be denied. This is a warranty of product reliability only and not a warranty of merchantability or fitness for a particular purpose. American Lighting Inc shall have no liability whatsoever in any event for payment of incidental or consequential damages, including, without limitations, installation costs and/or damages for personal injury and/or property. These products may represent a possible shock or fire hazard if improperly installed or altered in any way. This warranty does not apply to any product that has not been properly installed in accordance with current local codes and/or the National Electrical Code. Products that require a transformer, driver, or power supply must be used in conjunction with American Lighting Inc's recommended power supply to ensure safety and retain product warranty.

### PRODUCT SPECIFICATIONS

For the latest product information, updates, instructions and details concerning specifications, colors, finishes, performance, installation and design, visit [www.americanlighting.com](http://www.americanlighting.com). Color may vary from the color printed herein due to limitations in photographic and printing processes. American Lighting Inc. reserves the right to change product specifications without notice. Other product specifications such as color temperature, wavelength characteristics and lumen output are subject to production limitations and may vary. LED technology is changing rapidly, and not all color temperatures and performance levels can be duplicated at a later time. Best practices include purchasing 10-15% more for a particular project on the same initial order where white LED color temperatures must be maintained over project and product life. Eventual product replacement should be considered at layout and design stages. Best practices also include testing connections and product performance prior to mounting and/or installing.

### AVERAGE LIFE

Average incandescent lamp life, rated life and average life are terms used to describe the number of hours at which half of the lamps have failed. For LEDs, the hours of rated life specify the point where 70% of original lumen output is reached. Below this point, the effective life is over, however, the LED may still emit light. Individual results may vary with actual environmental conditions including, but not limited to, proper installation, ambient temperature and/or input voltage fluctuations.