

# ADAPTIVE 30W

## Dimmable 12 & 24VDC Power Supply

The Adaptive LED Driver series are class 2 rated and designed to operate with any standard ELV, MLV, & Incandescent TRIAC (Leading edge) dimmer switch and is forward phase and reverse phase compatible. Encased in a low profile aluminum enclosure that includes knock-outs for easy and quick installation makes it the perfect choice for under cabinet lights, tape light and various LED fixture installations.

- 12V or 24V DC constant voltage hardwire driver
- Dimmable with standard TRIAC, MLV, and ELV dimmers
- Forward phase and reverse phase compatible
- Short circuit, over-load, and over-temperature protections
- Slim, compact aluminum housing design (only 1.02" tall)
- Integrated wiring compartment
- PWM Output with 10-100% load operation
- Free air convection cooling
- Class 2, Class P, Type HL, FCC compliant, cULus Listed, Wet location rated



PROJECT: \_\_\_\_\_

TYPE: \_\_\_\_\_

LOCATION: \_\_\_\_\_

CATALOG NUMBER: \_\_\_\_\_



### ADAPTIVE - 30W QUICK SPECS

<b>SERIES</b>	ADPT-DRJ 30W
<b>INPUT VOLTAGE</b>	100-277V AC
<b>INPUT CURRENT</b>	0.5A@100V
<b>OUTPUT VOLTAGE</b>	12VDC or 24VDC
<b>RATED CURRENT</b>	2.5A@12VDC / 1.25A@24VDC
<b>POWER FACTOR</b>	0.99@120V / 0.98@277V
<b>MIN LOAD</b>	3W
<b>MAX LOAD</b>	30W
<b>EFFICIENCY</b>	> 79%
<b>DIMENSIONS</b>	6.49" (165mm) L x 3.6" (90mm) W x 1.02" (40mm) H
<b>DIMMING</b>	Phase Dimming / MLV / ELV / TRIAC
<b>STORAGE TEMP</b>	-40°F to 176°F (-40°C to 80°C)
<b>AMBIENT TEMP</b>	-40°F to 140°F (-40°C to 60°C)
<b>OPERATING TEMP</b>	-40°F to 140°F (-40°C to 60°C) — See Derating Curve
<b>RATING</b>	cULus Listed for Wet locations

### ADAPTIVE - 30W QUICK DIMENSIONS

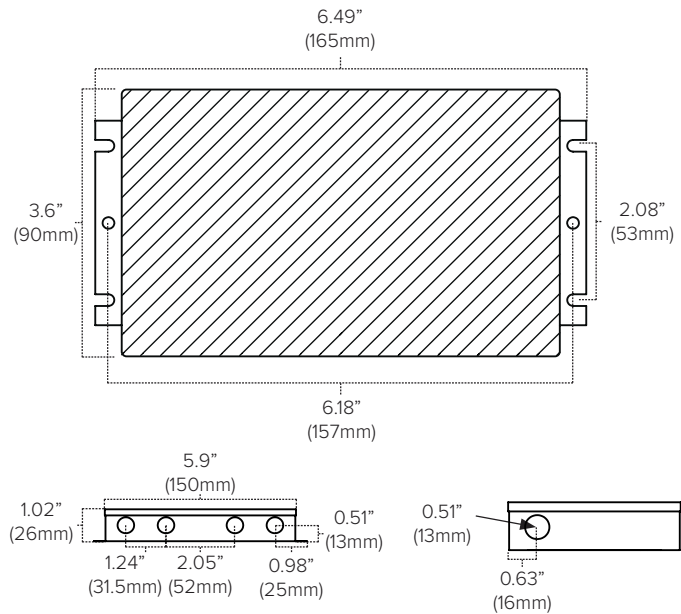

### ADAPTIVE - 30W ORDERING INFORMATION

ITEM NUMBER	DESCRIPTION
PLX-ADPTDRJ12V-30	Adaptive Pro 12V - 30W Power Supply
PLX-ADPTDRJ24V-30	Adaptive Pro 24V - 30W Power Supply

### ADAPTIVE - 30W QUICK SET UP

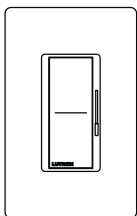

Dimmer Switch



Adaptive 30W Power Supply



24V LED Fixture

**ADAPTIVE - 30W TRIAC/ELV/MLV DIMMING WIRING DIAGRAM**

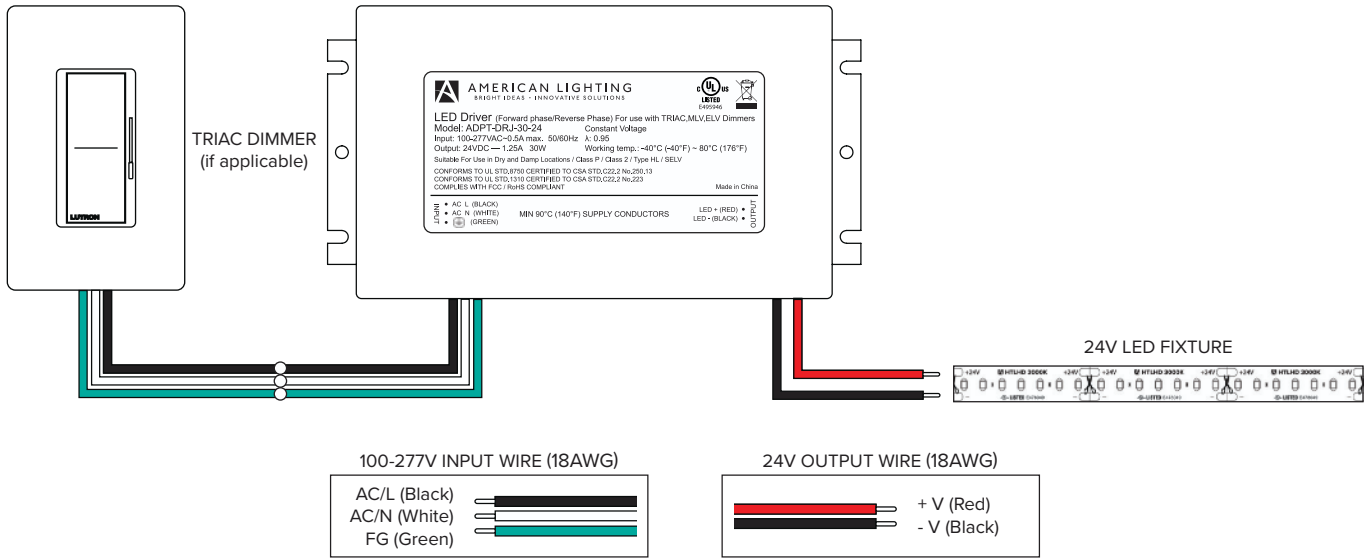

LOAD	
0-100% LOAD	UP TO 40°C (104°F)
80% LOAD	UP TO 50°C (122°F)
60% LOAD	UP TO 60°C (140°F)
0% LOAD	STORAGE ONLY UP TO 80°C (176°F)

ENVIRONMENT	
SERIES	ADPT-DRJ 30W
WORKING TEMPERATURE	-40°C~+60°C. (See Derating Curve below)
WORKING HUMIDITY	20~90%RH, Non-condensing
STORAGE TEMPERATURE HUMIDITY	-40°C~+80°C, -40°C~+80°C, 10~95%RH

**DERATING CURVE**

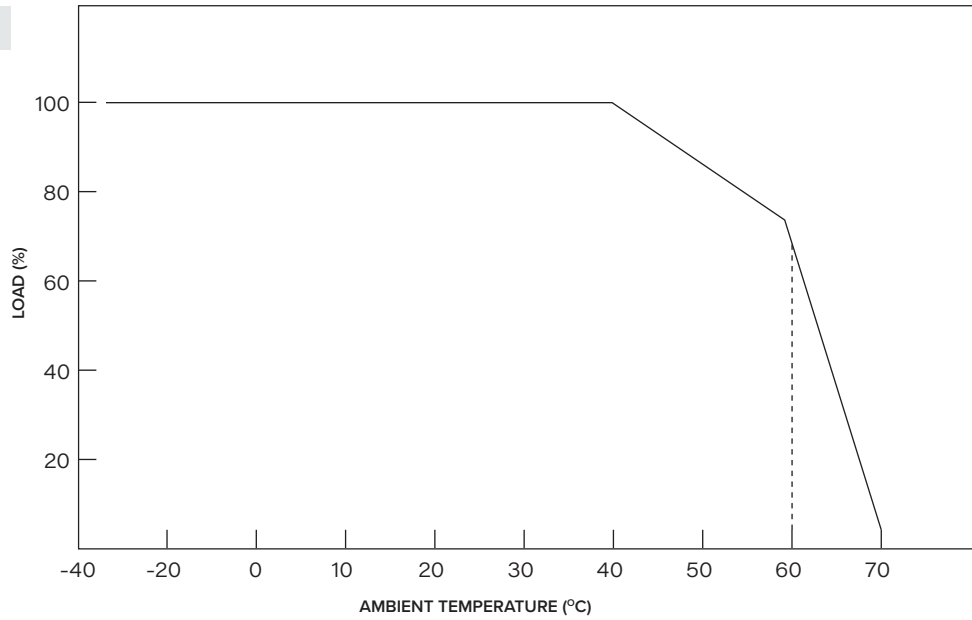



# PROLUXE LIGHTING WARRANTY

## LIMITED WARRANTY FOR LED PRODUCTS: 2 YEARS

### LIMITED PRODUCT WARRANTY

Our products are warranted to be free from defects in material and workmanship for the warranty period listed. Warranty periods begin from the date of shipment from American Lighting Inc's warehouse to the original purchaser. Products that prove to be defective during their specific warranty period will be either repaired or replaced, at the sole discretion of American Lighting Inc. Claims for defective products must be submitted in writing to American Lighting Inc's RGA Department within the warranty period. Upon approval of such return, American Lighting Inc reserves the right to inspect the product for misuse or abuse. Claims for indirect or consequential damages or for product that, in American Lighting Inc's opinion, has been misused will be denied. This is a warranty of product reliability only and not a warranty of merchantability or fitness for a particular purpose. American Lighting Inc shall have no liability whatsoever in any event for payment of incidental or consequential damages, including, without limitations, installation costs and/or damages for personal injury and/or property. These products may represent a possible shock or fire hazard if improperly installed or altered in any way. This warranty does not apply to any product that has not been properly installed in accordance with current local codes and/or the National Electrical Code. Products that require a transformer, driver, or power supply must be used in conjunction with American Lighting Inc's recommended power supply to ensure safety and retain product warranty.

### PRODUCT SPECIFICATIONS

For the latest product information, updates, instructions and details concerning specifications, colors, finishes, performance, installation and design, visit [www.americanlighting.com](http://www.americanlighting.com). Color may vary from the color printed herein due to limitations in photographic and printing processes. American Lighting Inc. reserves the right to change product specifications without notice. Other product specifications such as color temperature, wavelength characteristics and lumen output are subject to production limitations and may vary. LED technology is changing rapidly, and not all color temperatures and performance levels can be duplicated at a later time. Best practices include purchasing 10-15% more for a particular project on the same initial order where white LED color temperatures must be maintained over project and product life. Eventual product replacement should be considered at layout and design stages. Best practices also include testing connections and product performance prior to mounting and/or installing.

### AVERAGE LIFE

Average incandescent lamp life, rated life and average life are terms used to describe the number of hours at which half of the lamps have failed. For LEDs, the hours of rated life specify the point where 70% of original lumen output is reached. Below this point, the effective life is over, however, the LED may still emit light. Individual results may vary with actual environmental conditions including, but not limited to, proper installation, ambient temperature and/or input voltage fluctuations.