

# Control® 25-1

Professional Series – Compact Indoor/Outdoor Background/Foreground Speaker



## Key Features:

- Components:
  - 5-1/4" woofer with woven fiberglass cone
  - 3/4" PEI diaphragm tweeter with fluid cooling
- Contemporary, high-design appearance
- Built-in InvisiBall® mounting hardware\*, plus available U-bracket
- Weather resistant enclosure and transducers
- Wide 100° x 100° coverage
- 100 Watt power handling (200 Watt program) in direct 8Ω setting, plus built-in 30 Watt 70V/100V multi-tap transformer
- High fidelity sound character with broad frequency response of 60 Hz – 20 kHz



## Description:

The Control 25-1 is a two-way 5" speaker with rich sonic character, wide coverage, consistent dispersion, versatile mounting, and a contemporary high-design look that fits into a wide range of decors. This makes Control 25-1 an excellent choice for a wide variety of applications, including retail stores, restaurants, health clubs, theme parks, educational facilities, hospitality, music cafes, leisure venues, and anywhere where a top quality high-output indoor/ outdoor foreground/background music (and/or paging) speaker is required.

The unique InvisiBall mounting hardware is included with each system, making short work of permanent installation. The InvisiBall mounting method provides a high degree of both vertical and horizontal rotation, and because InvisiBall adjustments are made through a hidden access behind the logo badge, the grille never needs to be removed, and there exists a high degree of theft deterrence as well. Integrated M6 mounting points for an optional U-bracket adds to the installation versatility.

The LF driver's woven fiberglass cone provides durability and weather capable performance. The light weight high temperature fiberglass voice coil former and high temperature voice coil wire ensure high sensitivity and high power handling, while also providing stable performance under long-term high-power working conditions. The pure butyl rubber surround delivers clean sound and robust operation. JBL's WeatherEdge™ is a seamless, rubberized extension of the woofer surround that provides added protection to critical transducer elements. Cone geometry is optimized for smooth frequency response and consistent off-axis performance, while an FEA-optimized motor construction and linear suspension spider helps to lower harmonic distortion.

The HF driver's low viscosity ferro-magnetic fluid increases voice coil cooling for higher long-term power handling. The softened PEI diaphragm delivers a smooth and pure high frequency sound quality. The light weight Kapton™ voice coil former increases durability while providing better high frequency response extension. All these factors also contribute toward making the driver especially rugged for outdoors and other stressful applications.

In addition to the driver designs contributing toward a high degree of weather resistance, the cabinet provides excellent endurance against sun, salt and moisture. Grilles are heavily zinc-plated and finished in a tough, high-grade powder coating for rust resistance. The optional MTC-25WMG WeatherMax™ grilles are available for especially difficult environments and to break up driving rain. Connection is made via weather-capable screw-down terminals. The optional MTC-PC2 and MTC-PC3 panel covers are available to protect the terminal compartment, providing a water-tight sealed gland-nut entrance (when used with round-jacketed cable within the specified diameter range).

The frequency response is extremely smooth, resulting in a very natural sound character, and the response extends down to 60 Hz, providing strong bass capability. The system is capable of handling 100 Watts continuous pink noise (200 Watts program) at its 8 ohm setting and is also equipped with a built-in 30 Watt 70V/100V multi-tap transformer for operation on distributed speaker lines. The combination of high sensitivity and power handling provides high Max SPL of 110 dB.

The Control 25-1 readily accepts a variety of paints and finishes to match any décor. Available in black or white (-WH).

# Control® 25-1

Professional Series – Compact Indoor/Outdoor Background/Foreground Speaker



## Specifications:

System	
Frequency Range (-10 dB) <sup>1</sup>	60 Hz – 20 kHz
Frequency Response (+/-3 dB)	85 Hz – 17 kHz
Power Rating <sup>2</sup>	200 W Continuous Program (2 hrs) 100 W (400W peak) Continuous Pink Noise (2 hrs) 75 W (300W peak) Continuous Pink Noise (100 hrs)
Maximum Input Voltage	25.3 V RMS (2 hrs), 50.6 V peak
Maximum SPL <sup>3</sup>	110 dB average Continuous Pink Noise (116 dB peak)
Sensitivity <sup>4</sup>	90 dB, 1W/1m (averaged 100 Hz – 10 kHz)
Coverage Angle <sup>5</sup>	100° x 100°
Directivity Factor (Q)	6.04 (averaged 1 kHz – 16 kHz)
Directivity Index (DI)	7.6 dB (averaged 1 kHz – 16 kHz)
Nominal Impedance	8 ohms (THRU setting)
Crossover Type	2nd order low-pass, 3rd order high-pass
Circuitry	
Transformer Taps	70V: 30W, 15W, 7.5W, 3.7W 100V: 30W, 15W, 7.5W Insertion Loss <0.94 dB at any tap setting Thru Setting: 8Ω nominal
Recommended Protective High-Pass <sup>6</sup>	60 Hz high-pass (24 dB/oct) (for 8Ω operation and for all 70V/100V tap settings)
Transducers	
Low Frequency	135 mm (5.25 in), woven-fiberglass cone with pure butyl rubber surround with Weather-Edge frame protection, high-temp fiberglass voice coil former, high-temp voice coil wire, optimized cone geometry, linear suspension spider, and FEA optimized motor structure.
High Frequency	19 mm (0.75 in) PEI diaphragm, low-viscosity ferro-magnetic fluid, and lightweight Kapton™ voice coil former.
Physical	
Enclosure Material	High Impact Polystyrene (HIPS), painted with highly-UV resistant paint on white (-WH) version for maximum UV fade resistance.
Grille	Highly zinc-plated, finished in durable TGIC polyester powder coating. MTC-25WMG-1 (&-WH) available with Weather-Max™ multi-layer foam and tight-weave mesh vapor barrier backing.
Installation	InvisiBall wall-mounting system included. Two 6 mm attachment points (on top and bottom) for optional MTC-25UB-1 (&-WH) U-bracket. Secondary safety attachment loop point on back panel.

Environmental	IP-44 per IEC529 (IP-55 when installed with the optional MTC-25WMG-1 WeatherMax™ grille and either MTC-PC2 or MTC-PC3 panel cover.) Exceeds MilSpec 810 for humidity, salt-spray, temperature & UV. Passes MilStd-202F for salt spray and ASTM G85 for acid-air plus salt spray. Optional MTC-25WMG-1 WeatherMax™ grille for breaking up driving rain and for especially difficult environments.
Termination	Screw-down terminal strip, zinc-plated copper based, nickel-plated metal screws and washers. Accepts up to 9 mm outside 4 mm inside open lugs (#6, #8, or #10 lug), plus bare wire (up to 12 AWG / 2.5 mm <sup>2</sup> ). Optional MTC-PC2 and MTC-PC3 protective panel covers available to provide sealed entrance for additional weather protection.
Agency Rating	ROHS-compliant; Transformer UL Recognized per UL1876
Colors	Black (RAL9004) or white (-WH, RAL9016)
Dimensions (H x W x D) <sup>7</sup>	243 x 188 x 145 mm (9.6 x 7.4 x 5.7 in); 203 mm (8.0 in) deep total when mounted on InvisiBall wall-mount bracket.
Net Weight (each)	3.4 kg (7.5 lb)
Shipping Weight (pair)	8.16 kg (18 lb)
Included Accessories	InvisiBall™ wall-mounting system), 6 mm x 100 mm hex key
Optional Accessories	» MTC-25UB-1 – Yolk-type U-bracket (&-WH) » MTC-25WMG-1 – WeatherMax grille with backing (&-WH) » MTC-28/25CM – Ceiling-Mount InvisiBall adapter (&-WH)

<sup>1</sup> In half-space (on-wall, 2pi)

<sup>2</sup> At 8Ω setting. Continuous Pink Noise rating is IEC-shaped pink noise with a 6 dB crest factor. Continuous Program Power is defined as 3 dB above the Continuous Pink Noise Rating and is a conservative expression of the system's ability to handle normal speech and music program material.

<sup>3</sup> Calculated from sensitivity and power handling, exclusive of power compression, at THRU setting

<sup>4</sup> Half-space (on-wall), averaged 100 Hz – 10 kHz, 2.83V

<sup>5</sup> Coverage angle (-6 dB), average between 1 kHz and 12 kHz

<sup>6</sup> For protection against driving below resonant frequency and to keep transformer out of saturation

<sup>7</sup> In vertical orientation

# Control® 25-1

Professional Series – Compact Indoor/Outdoor Background/Foreground Speaker



## Mounting Dimensions:

Dimensions in mm (inches)

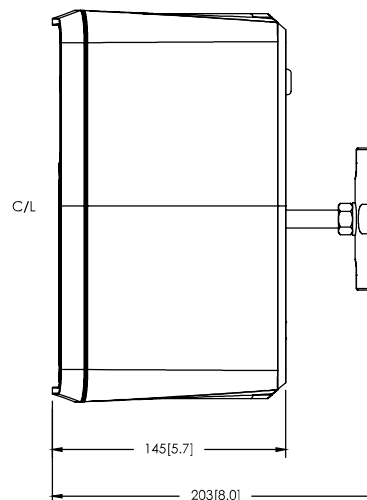
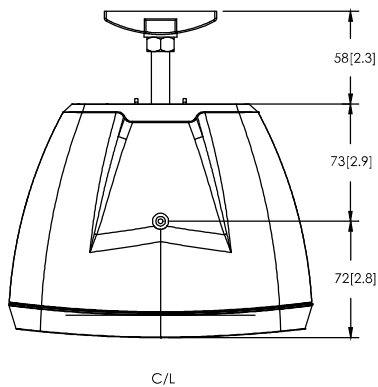
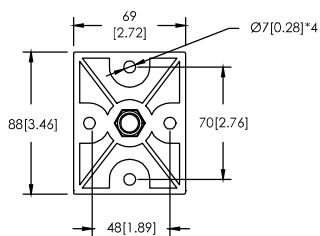
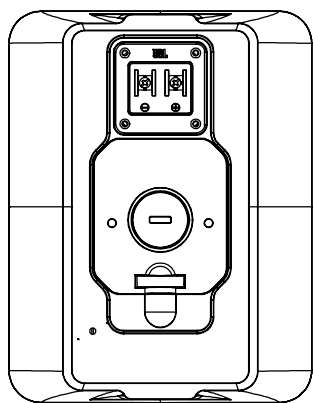
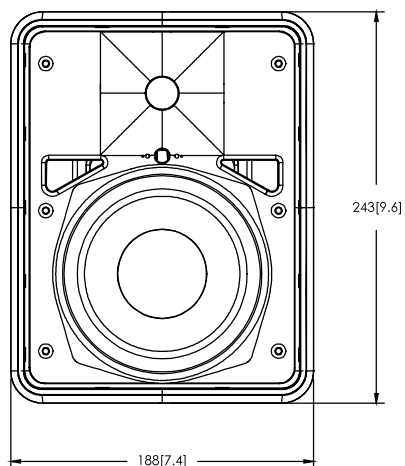

## Frequency Response:

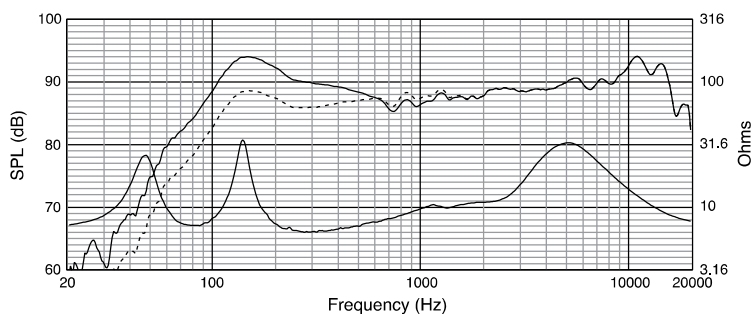

On-axis in half-space (2pi, solid line) and full-space (4pi, dotted line) at thru (8Ω) setting Input Impedance

## Beamwidth vs. Frequency:

