

---

# INSTALLATION INSTRUCTIONS

---

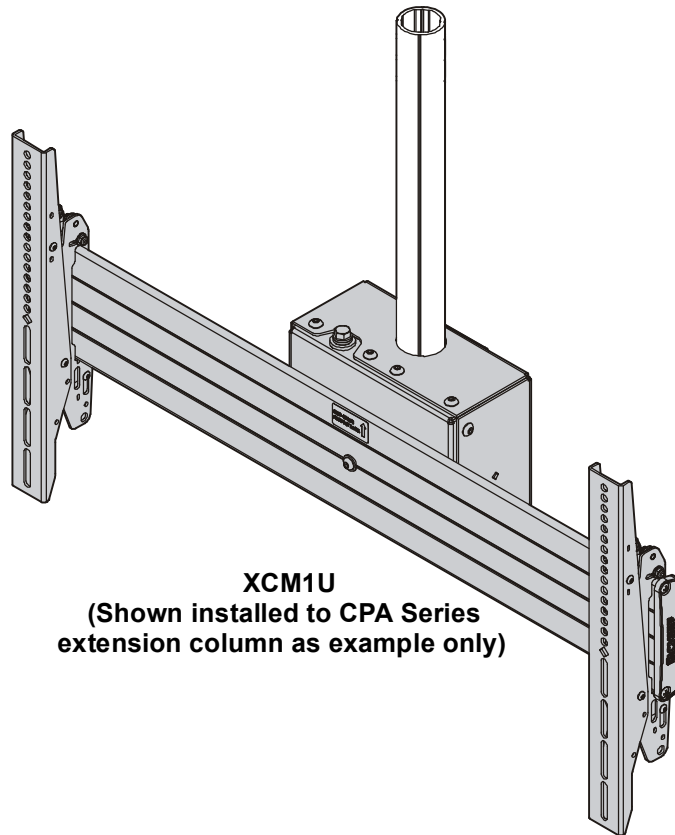

**XCM1U**  
(Shown installed to CPA Series  
extension column as example only)

---

## Extra Large Flat Panel Ceiling Mount

---

## DISCLAIMER

Milestone AV Technologies and its affiliated corporations and subsidiaries (collectively "Milestone"), intend to make this manual accurate and complete. However, Milestone makes no claim that the information contained herein covers all details, conditions or variations, nor does it provide for every possible contingency in connection with the installation or use of this product. The information contained in this document is subject to change without notice or obligation of any kind. Milestone makes no representation of warranty, expressed or implied, regarding the information contained herein. Milestone assumes no responsibility for accuracy, completeness or sufficiency of the information contained in this document.

Chief® is a registered trademark of Milestone AV Technologies. All rights reserved.

## DEFINITIONS

**MOUNTING SYSTEM:** A MOUNTING SYSTEM is the primary Chief product to which an accessory and/or component is attached.

**ACCESSORY:** AN ACCESSORY is the secondary Chief product which is attached to a primary Chief product, and may have a component attached or setting on it.

**COMPONENT:** A COMPONENT is an audiovisual item designed to be attached or resting on an accessory or mounting system such as a video camera, CPU, screen, display, projector, etc.



**WARNING:** A WARNING alerts you to the possibility of serious injury or death if you do not follow the instructions.



**CAUTION:** A CAUTION alerts you to the possibility of damage or destruction of equipment if you do not follow the corresponding instructions.



## IMPORTANT SAFETY INSTRUCTIONS



**WARNING:** Failure to read, thoroughly understand, and follow all instructions can result in serious personal injury, damage to equipment, or voiding of factory warranty! It is the installer's responsibility to make sure all mounting systems are properly assembled and installed using the instructions provided.



**WARNING:** Failure to provide adequate structural strength for this mounting system can result in serious personal injury or damage to equipment! It is the installer's responsibility to make sure the structure to which this mounting system is attached can support five times the combined weight of all equipment. Reinforce the structure as required before installing the mounting system.



**WARNING:** Exceeding the weight capacity can result in serious personal injury or damage to equipment! It is the installer's responsibility to make sure the combined weight of all components located within the mounting system of the XCM1U model does not exceed 250 lbs (113.4 kg).



**WARNING:** Use this mounting system only for its intended use as described in these instructions. Do not use attachments not recommended by the manufacturer.



**WARNING:** Never operate this mounting system if it is damaged. Return the mounting system to a service center for examination and repair.



**WARNING:** Do not use this product outdoors.

**NOTE:** The XCM1U flat panel ceiling mount is designed to be mounted to a 1-1/2" NPT or NPSM following ANSI/ASME B1.20.1 (Schedule 40, 0.154" minimum thickness steel or aluminum-ASTM B221) threaded extension column (not included); or a UL Listed CPA extension column and UL Listed CPA Ceiling Plates (not included): CPA330, CPA365, CPA395.







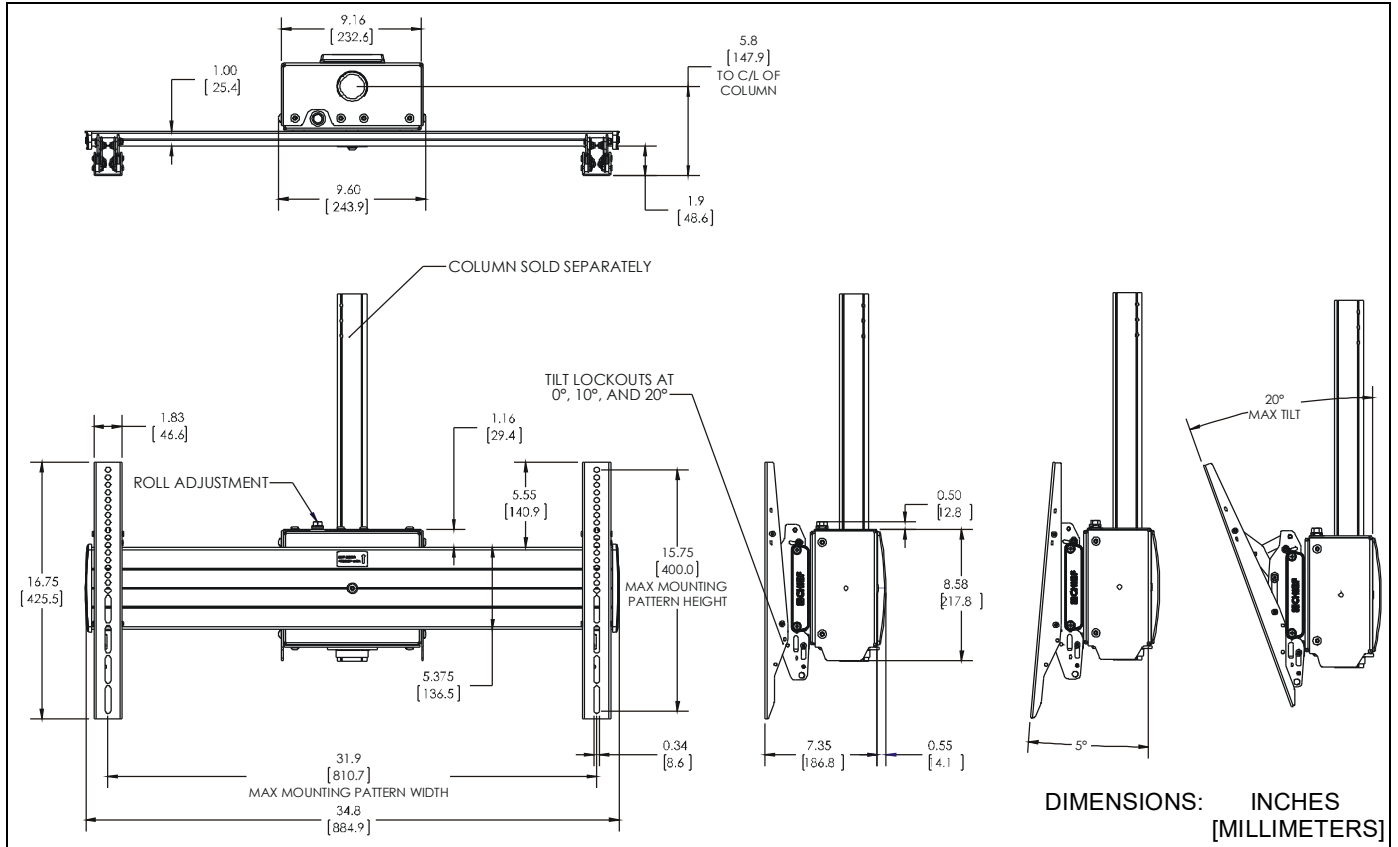





The following UL Listed Chief ceiling plates WITHOUT swaged collars (not included) may also be used: CMA330, CMA345, CMA395.

**--SAVE THESE INSTRUCTIONS--**

**DIMENSIONS**



## LEGEND

	<b>Tighten Fastener</b> Apretar elemento de fijación Befestigungsteil festziehen Apertar fixador Serrare il fissaggio Bevestiging vastdraaien Serrez les fixations		<b>Pencil Mark</b> Marcar con lápiz Stiftmarkierung Marcar com lápis Segno a matita Potloodmerkteken Marquage au crayon
	<b>Loosen Fastener</b> Aflojar elemento de fijación Befestigungsteil lösen Desapertar fixador Allentare il fissaggio Bevestiging losdraaien Desserrez les fixations		<b>Drill Hole</b> Perforar Bohrloch Fazer furo Praticare un foro Gat boren Percez un trou
	<b>Phillips Screwdriver</b> Destornillador Phillips Kreuzschlitzschraubendreher Chave de fendas Phillips Cacciavite a stella Kruiskopschroevendraaier Tournevis à pointe cruciforme		<b>Adjust</b> Ajustar Einstellen Ajustar Regolare Afstellen Ajuster
	<b>Open-Ended Wrench</b> Llave de boca Gabelschlüssel Chave de bocas Chiave a punte aperte Steeksleutel Clé à fourche		<b>Remove</b> Quitar Entfernen Remover Rimuovere Verwijderen Retirez
	<b>By Hand</b> A mano Von Hand Com a mão A mano Met de hand À la main		<b>Optional</b> Opcional Optional Opcional Opzionale Optie En option
	<b>Hex-Head Wrench</b> Llave de cabeza hexagonal Sechskantschlüssel Chave de cabeça sextavada Chiave esagonale Zeskantsleutel Clé à tête hexagonale		<b>Security Wrench</b> Llave de seguridad Sicherheitsschlüssel Chave de segurança Chiave di sicurezza Veiligheidssleutel Clé de sécurité

**TOOLS REQUIRED FOR INSTALLATION**

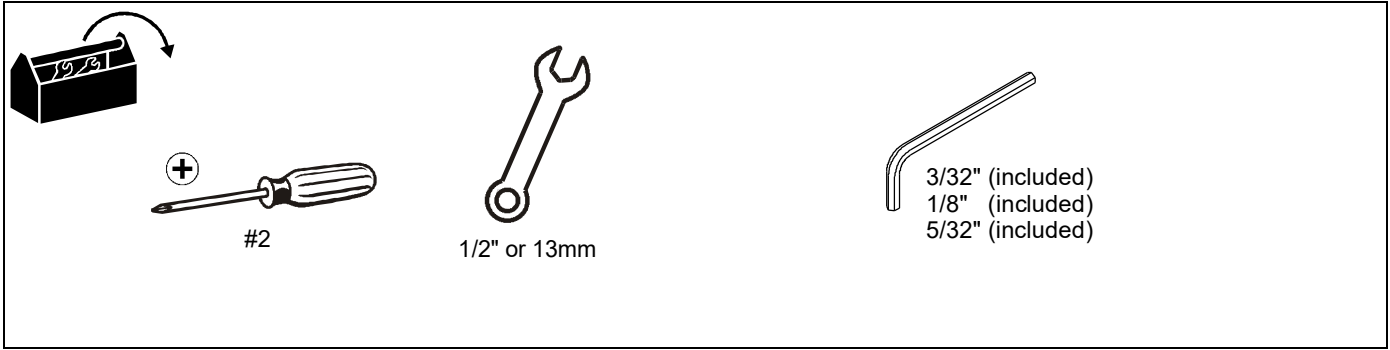

**PARTS**

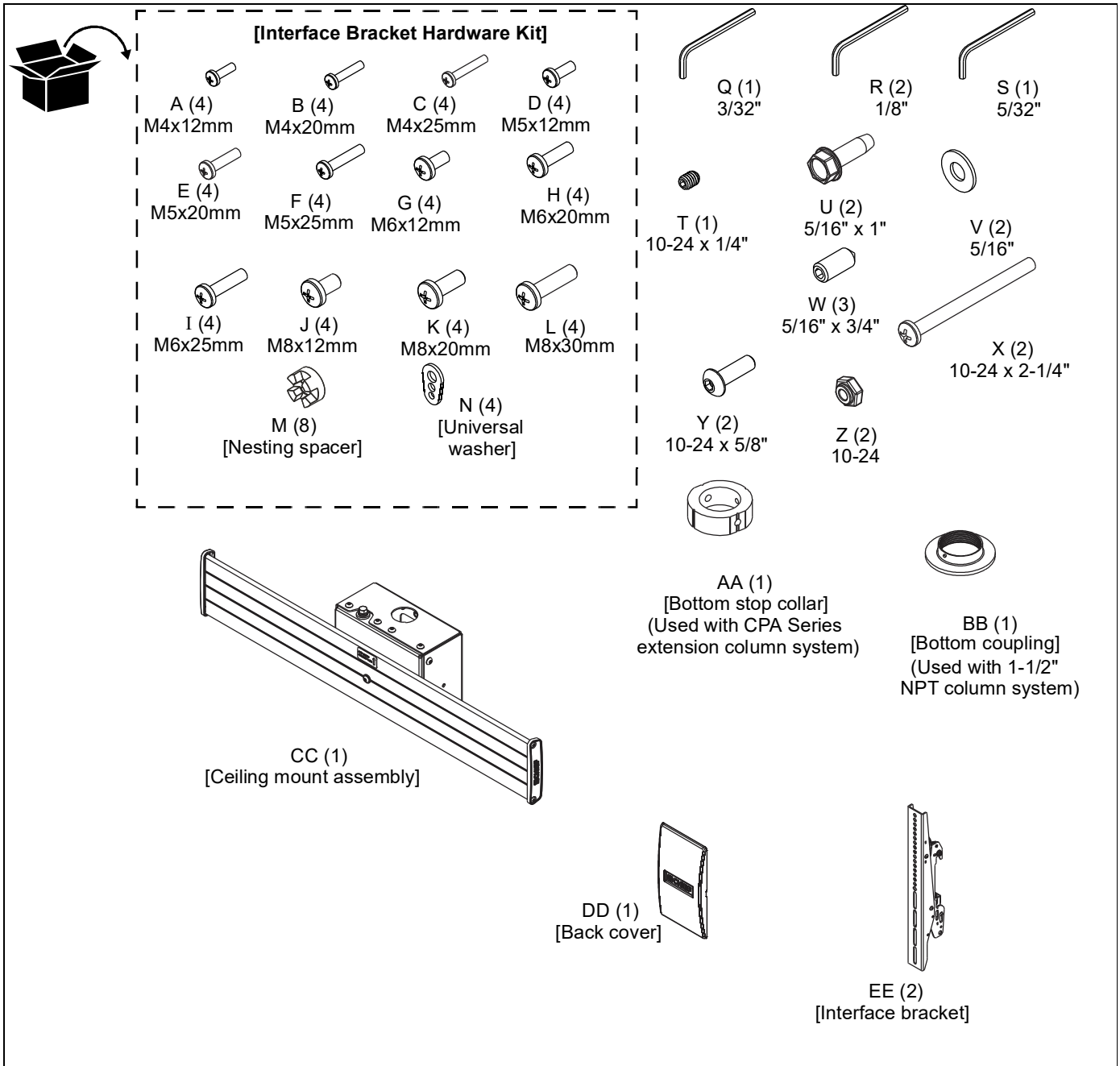

## INSTALLATION

**IMPORTANT ! :** The following procedure assumes that:

- a UL Listed CPA or CMA ceiling plate (not included); AND
- a 1-1/2" NPT or NPSM following ANSI/ASME B1.20.1 (Schedule 40, 0.154" minimum thickness steel or aluminum-ASTM B221) threaded extension column (not included); OR a UL Listed Chief CPA Series extension column (not included) has been properly installed following instructions provided with ceiling plate and extension column.

**NOTE:** Proceed to **Attaching Mount to NPT Column** section or **Attaching Mount to CPA Extension Column** section, as appropriate.

### Attaching Mount to 1-1/2" NPT Column



**CAUTION:** WATCH FOR PINCH POINTS! Do not place fingers between moveable parts.

1. Insert two 5/16 x 3/4" set screws (W) into back of ceiling mount (CC). (See Figure 1)

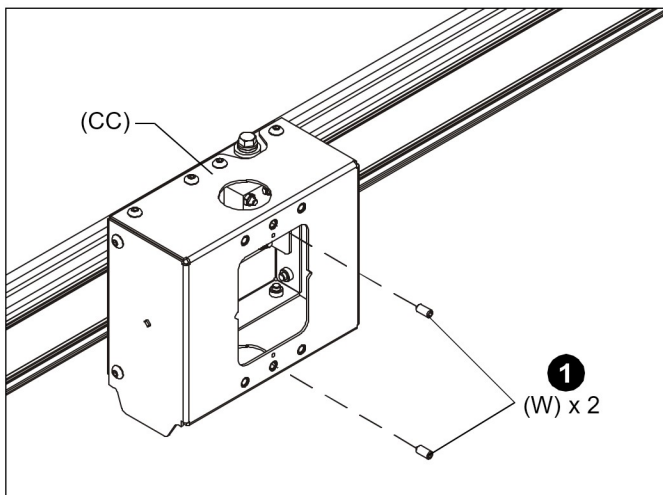

**Figure 1**

2. Slide ceiling mount (CC) up from below onto installed column (not included). (See Figure 2)
3. Tighten two 5/16" set screws installed in Step 1 against column.
4. Thread bottom coupling (BB) onto installed column until tight, with a minimum of four threads engaged. (See Figure 2)
5. Install and tighten one 10-24 x 1/4" set screw (T) into bottom coupling (BB). (See Figure 2)

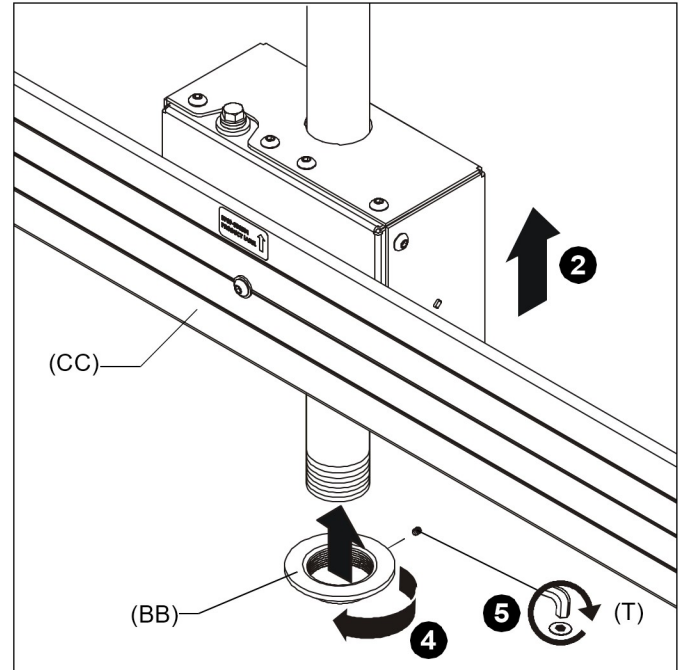

**Figure 2**

6. Loosen two installed set screws (W), and slide ceiling mount down extension column until it rests on the bottom coupling (B). (See Figure 3)
7. Retighten two 5/16" set screws (W) against column. (See Figure 3)

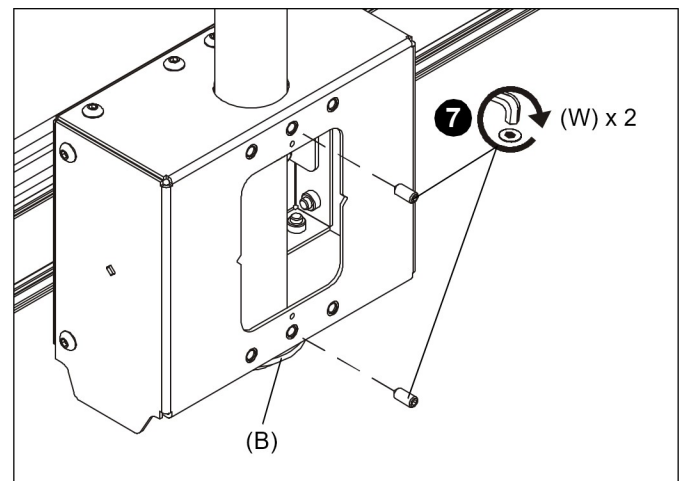

**Figure 3**

8. Proceed to **Attaching Interface Brackets to Display** section.

**Attaching Mount to CPA Extension Column**



**CAUTION:** WATCH FOR PINCH POINTS! Do not place fingers between moveable parts.

1. Insert two 5/16 x 3/4" set screws (W) into back of ceiling mount (CC). (See Figure 4)

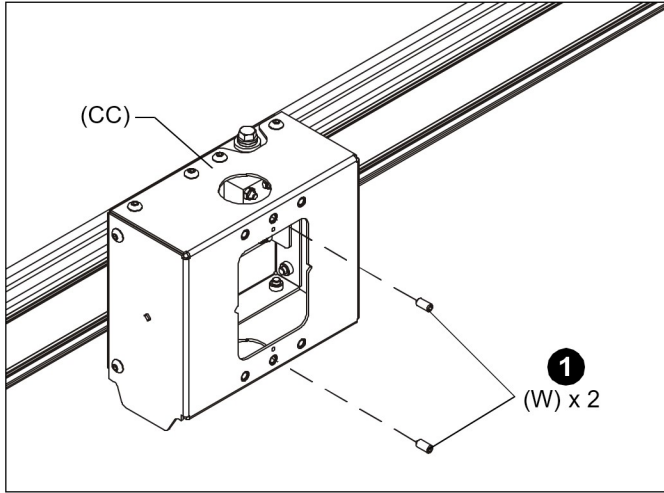

**Figure 4**

2. Slide ceiling mount (CC) up from below onto installed column (not included). (See Figure 5)
3. Tighten two 5/16" set screws installed in Step 1 against column.
4. Slide bottom stop collar (AA) onto installed column, lining up holes in collar with holes in column.

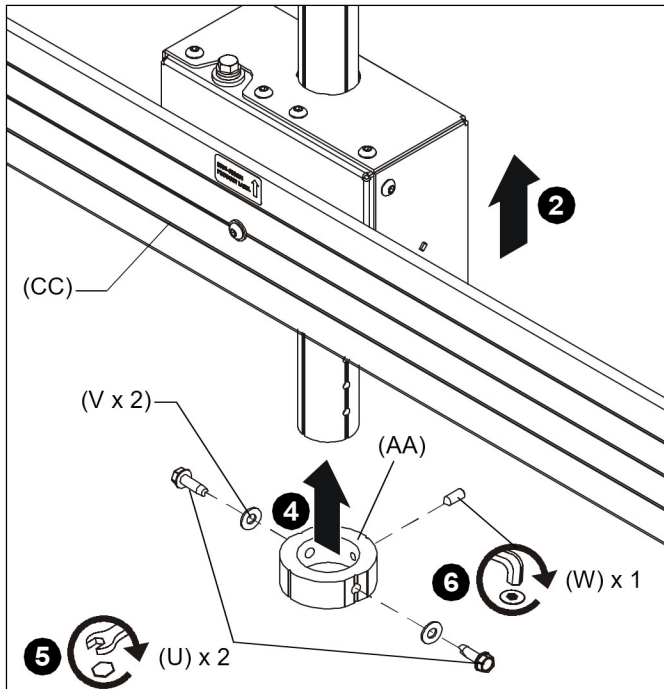

**Figure 5**

5. Install two 5/16" x 1" self-tapping screws (U) through two 5/16" flat washers (V), bottom stop collar (AA), and into installed column. (See Figure 5)
6. Install and tighten 5/16" x 3/4" set screw (W) into bottom stop collar (AA). (See Figure 5)
7. Slightly loosen two installed set screws (W) from ceiling mount (CC), and slide ceiling mount down extension column until it rests on the bottom stop collar (AA).
8. Retighten two 5/16" set screws (W) against column. (See Figure 6)

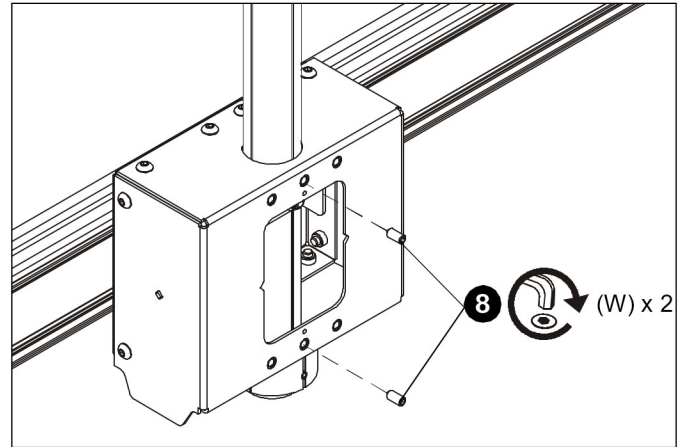

**Figure 6**

**Attaching Interface Brackets to Display**

1. Lower the latch mechanism on each interface bracket (EE). (See Figure 7)

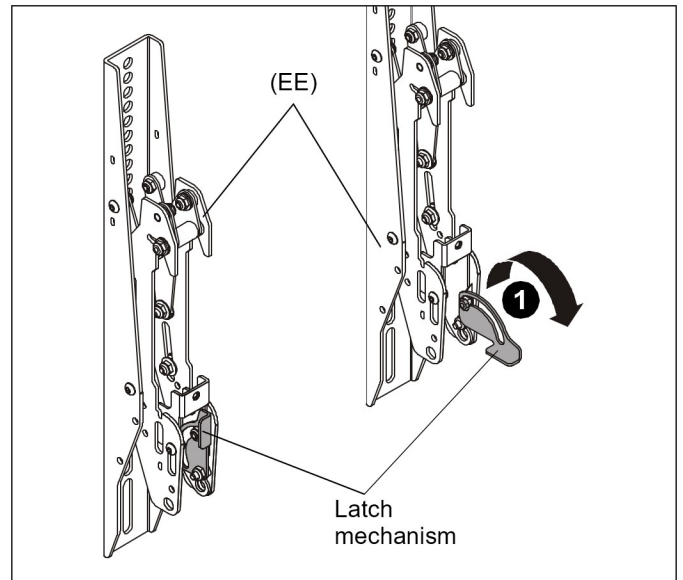

**Figure 7**

- Align the center of the interface bracket (EE) with center of screen. (See Figure 8)

**NOTE:** The diamond-shape hole in the bracket corresponds to the center of the mount.

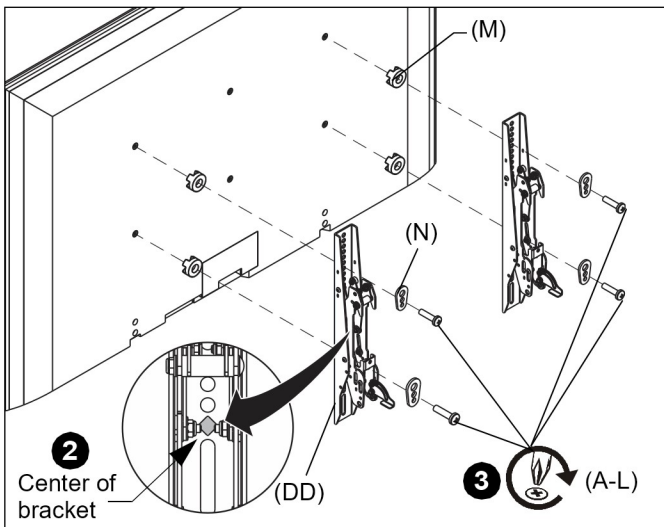

Figure 8

**WARNING:** IMPROPER INSTALLATION CAN LEAD TO DISPLAY FALLING CAUSING SERIOUS PERSONAL INJURY OR DAMAGE TO EQUIPMENT! Using screws of improper size may damage your display. Properly sized screws will easily and completely thread into display mounting holes. If spacers are required, be sure to use longer screws of the same diameter.

- Select correct screws, spacers (if necessary) and universal washers from the hardware bag (A-N) and attach brackets (EE) to back of screen. (See Figure 8)

**IMPORTANT ! :** The M8 screws do **NOT** require a washer. Use the universal washer (N) only with M4, M5 and M6 screws.

**NOTE:** The nesting spacers (M) may be used separately, or put two together in different configurations to create different size spacers. (See Figure 9)

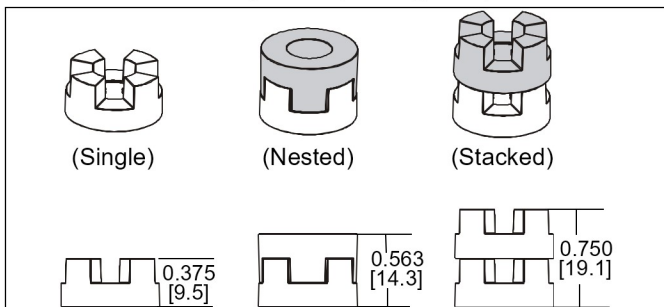

Figure 9

### Attaching Display to Ceiling Mount

- Ensure that the latch mechanisms on interface brackets (EE) are already lowered. (See Figure 7)
- While supporting both sides of display, lower display onto ceiling mount, hooking top of interface brackets onto front of ceiling mount. (See Figure 10)

**WARNING:** IMPROPER INSTALLATION CAN LEAD TO DISPLAY FALLING CAUSING SERIOUS PERSONAL INJURY OR DAMAGE TO EQUIPMENT! The display **MUST** be centered on the ceiling mount.

- Raise the latch mechanism on both interface brackets to lock bracket in place. (See Figure 10)

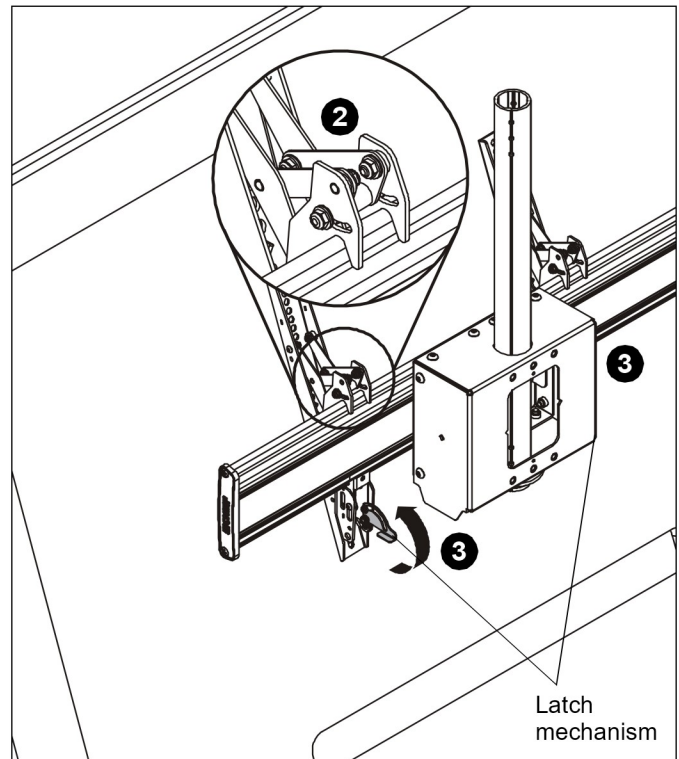

Figure 10

4. Fasten bracket against ceiling mount extrusion using one 10-24 x 5/8" button head cap screw (Y). (See Figure 11)
5. Repeat for other interface bracket.

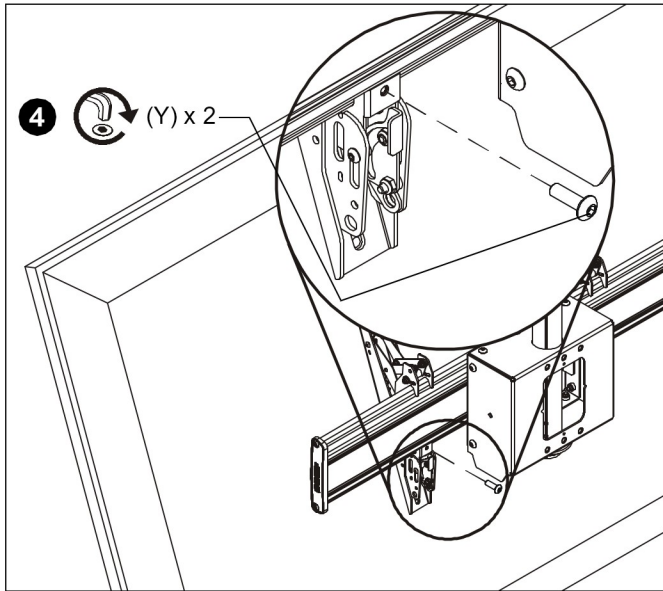

Figure 11

**Adjustments**



**CAUTION:** Watch for pinch points! Do not place fingers between moveable parts.

**Roll**

The ceiling mounts allow up to 3° roll each direction.

1. Turn the roll adjustment bolt in the direction necessary for the desired roll. (See Figure 12)
2. Stop adjusting when the desired setting is reached.

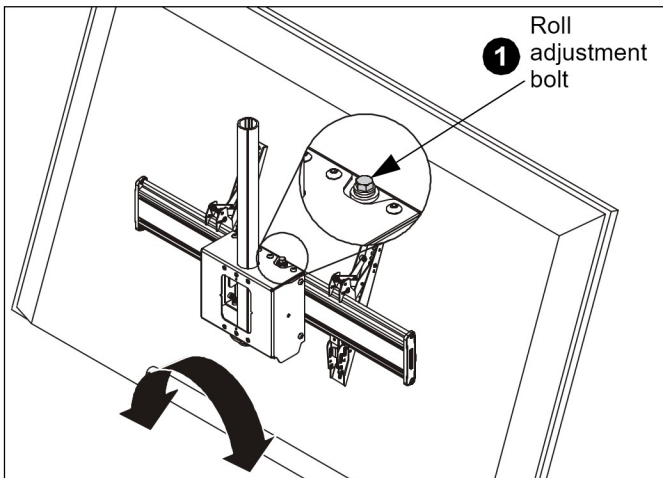

Figure 12

**Tilt**

The interface brackets allow -5° to 20° tilt, and can be locked at 0°, 10° and 20° tilt.

3. If necessary, loosen button head tilt friction bolt (located on side of interface bracket). (See Figure 13)
4. Adjust tilt as required. (See Figure 13)
5. The tilt may be locked at 0°, 10° and 20° using one 10-24 x 2-1/4" Phillips head screw (X) and one 10-24 lock nut (Z) per interface bracket. (See Figure 13)
6. Tighten button head tilt adjustment bolt as necessary.

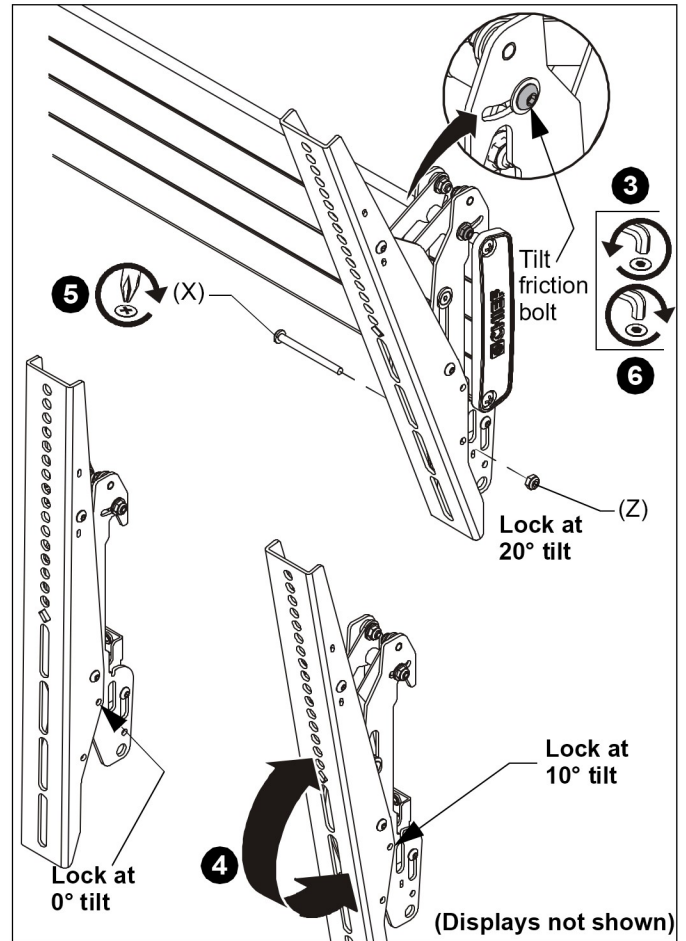
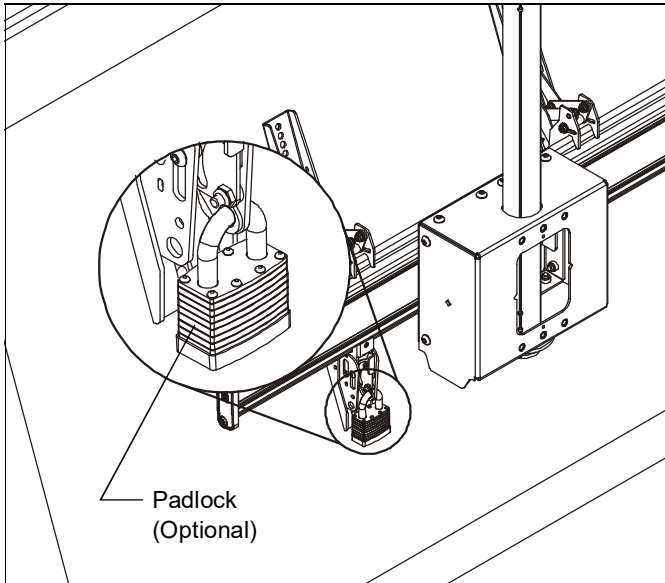

Figure 13

**OPTIONAL: Security**

1. **OPTIONAL:** Add padlock (not included) to each interface bracket to lock display to ceiling mount. (See Figure 14)

**Figure 14**

2. Install back cover (DD) into four holes on back of ceiling mount. (See Figure 15)

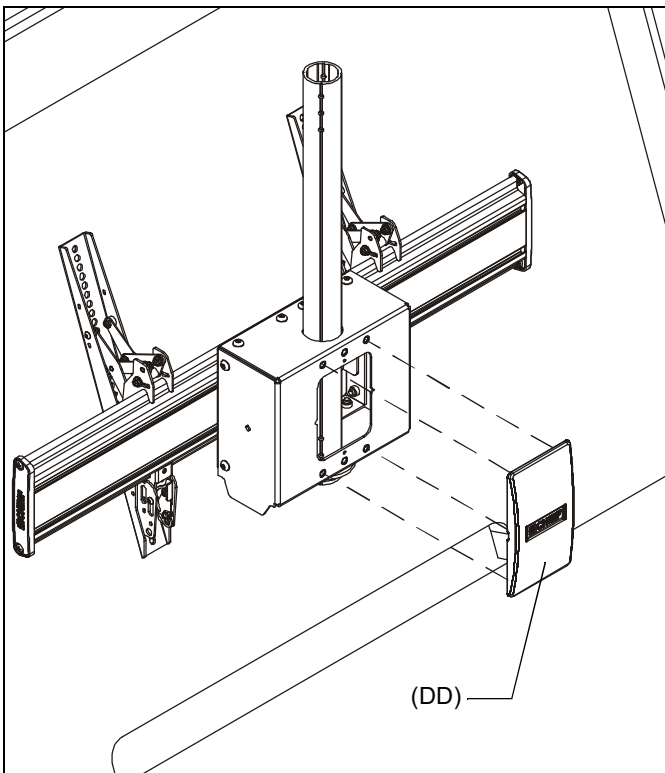
**Figure 15**





Our Mounts. **Your Vision.**

Chief, a products division of  
Milestone AV Technologies

8800-003043 Rev00  
©2018 Milestone AV Technologies  
[www.milestone.com](http://www.milestone.com)  
04/18

<b>USA/International</b>	<b>A</b> 6436 City West Parkway, Eden Prairie, MN 55344 <b>P</b> 800.582.6480 / 952.225.6000 <b>F</b> 877.894.6918 / 952.894.6918
<b>Europe</b>	<b>A</b> Franklinstraat 14, 6003 DK Weert, Netherlands <b>P</b> +31 (0) 495 580 852 <b>F</b> +31 (0) 495 580 845
<b>Asia Pacific</b>	<b>A</b> Office No. 918 on 9/F, Shatin Galleria 18-24 Shan Mei Street Fotan, Shatin, Hong Kong <b>P</b> 852 2145 4099 <b>F</b> 852 2145 4477

