

---

# INSTALLATION INSTRUCTIONS

---

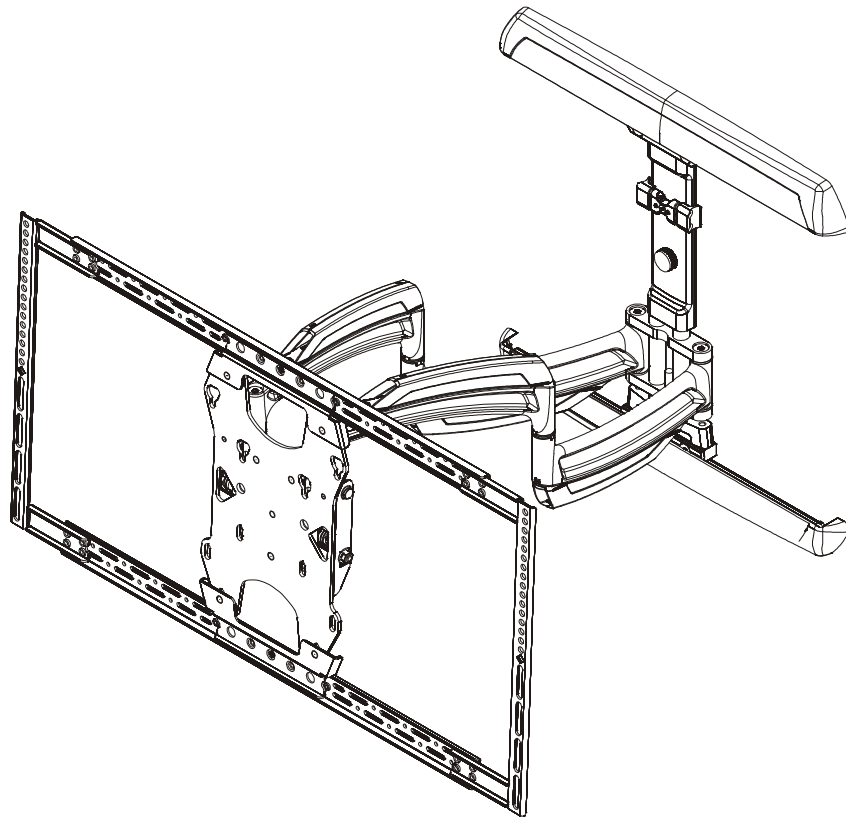

---

## Large Swing Arm Mounts

---

## DISCLAIMER

Legrand | AV and its affiliated corporations and subsidiaries (collectively "Legrand | AV"), intend to make this manual accurate and complete. However, Legrand | AV makes no claim that the information contained herein covers all details, conditions or variations, nor does it provide for every possible contingency in connection with the installation or use of this product. The information contained in this document is subject to change without notice or obligation of any kind. Legrand | AV makes no representation of warranty, expressed or implied, regarding the information contained herein. Legrand | AV assumes no responsibility for accuracy, completeness or sufficiency of the information contained in this document.

Chief® is a registered trademark of Legrand AV Inc.

## DEFINITIONS

**MOUNTING SYSTEM:** A MOUNTING SYSTEM is the primary Chief product to which an accessory and/or component is attached.

**ACCESSORY:** AN ACCESSORY is the secondary Chief product which is attached to a primary Chief product, and may have a component attached or setting on it.

**COMPONENT:** A COMPONENT is an audiovisual item designed to be attached or resting on an accessory or mounting system such as a video camera, CPU, screen, display, projector, etc.



**WARNING:** A WARNING alerts you to the possibility of serious injury or death if you do not follow the instructions.



**CAUTION:** A CAUTION alerts you to the possibility of damage or destruction of equipment if you do not follow the corresponding instructions.



## IMPORTANT SAFETY INSTRUCTIONS!



**WARNING:** Use this mounting system only for its intended use as described in these instructions. Do not use attachments not recommended by the manufacturer.



**WARNING:** Never operate this mounting system if it is damaged. Return the mounting system to a service center for examination and repair.



**WARNING:** Do not use this product outdoors.



**WARNING:** Failure to read, thoroughly understand, and follow all instructions can result in serious personal injury, damage to equipment, or voiding of factory warranty! It is the installer's responsibility to make sure all components are properly assembled and installed using the instructions provided.



**WARNING:** Failure to provide adequate structural strength for this component can result in serious personal injury or damage to equipment! It is the installer's responsibility to make sure the structure to which this component is attached can support five times the combined weight of all equipment. Reinforce the structure as required before installing the component.



**WARNING:** The wall to which the mount is being attached may have a maximum drywall thickness of 5/8" (1.6cm) when installing to wood studs or hollow concrete block. If installing to poured concrete, the wall CANNOT have ANY drywall covering!



**WARNING:** Exceeding the weight capacity can result in serious personal injury or damage to equipment! It is the installer's responsibility to make sure the combined weight of all components attached does not exceed 125 lbs (56.7 kg). Use with products heavier than the maximum weight indicated may result in collapse of the mount and its accessories causing possible injury.







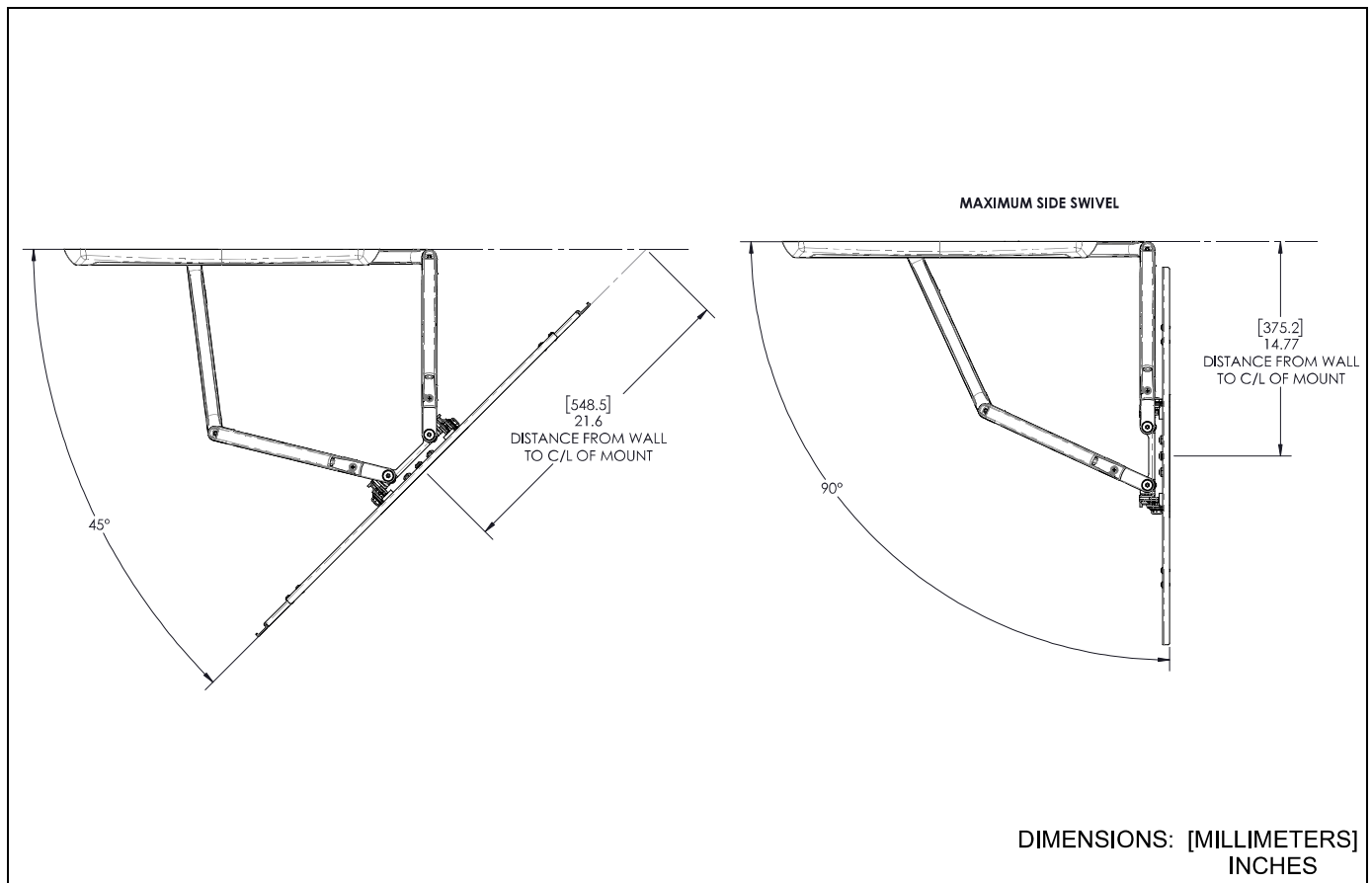
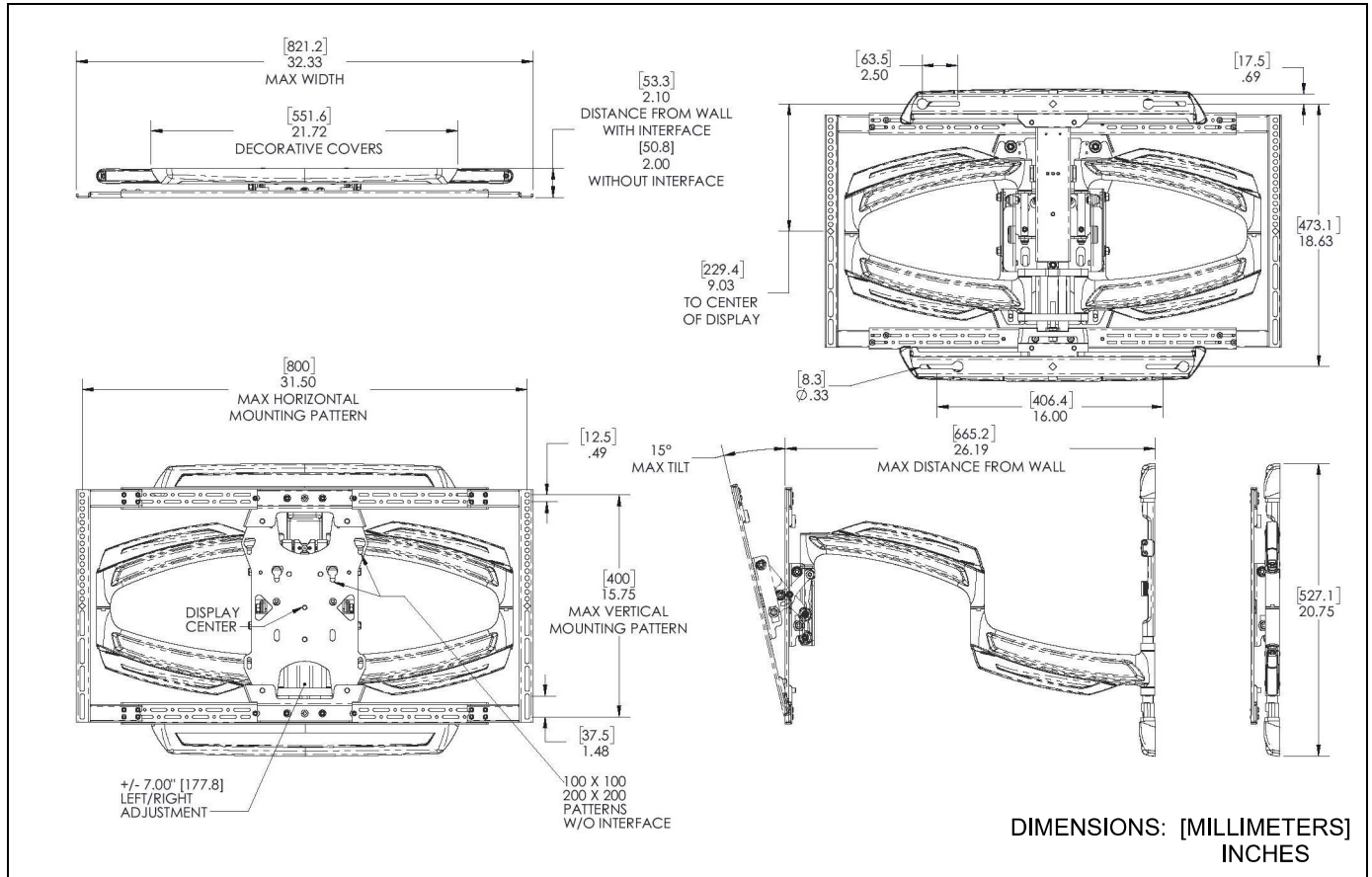



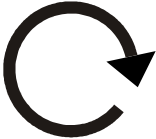

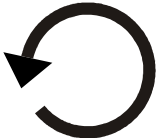
**IMPORTANT ! :** The TS525TU mount is designed to be mounted to an 8" concrete, 8"x8"x16" concrete block or 2" x 4" wood studs (16" on center) wall.

**--SAVE THESE INSTRUCTIONS!--**

**DIMENSIONS**



## LEGEND

	<b>Tighten Fastener</b> Apretar elemento de fijación Befestigungsteil festziehen Apertar fixador Serrare il fissaggio Bevestiging vastdraaien Serrez les fixations		<b>Pencil Mark</b> Marcar con lápiz Stiftmarkierung Marcar com lápis Segno a matita Potloodmerkten Marquage au crayon
	<b>Loosen Fastener</b> Aflojar elemento de fijación Befestigungsteil lösen Desapertar fixador Allentare il fissaggio Bevestiging losdraaien Desserrez les fixations		<b>Drill Hole</b> Perforar Bohrloch Fazer furo Praticare un foro Gat boren Percez un trou
	<b>Phillips Screwdriver</b> Destornillador Phillips Kreuzschlitzschraubendreher Chave de fendas Phillips Cacciavite a stella Kruiskopschroevendraaier Tournevis à pointe cruciforme		<b>Adjust</b> Ajustar Einstellen Ajustar Regolare Afstellen Ajuster
	<b>Open-Ended Wrench</b> Llave de boca Gabelschlüssel Chave de bocas Chiave a punte aperte Steeksleutel Clé à fourche		<b>Remove</b> Quitar Entfernen Remover Rimuovere Verwijderen Retirez
	<b>By Hand</b> A mano Von Hand Com a mão A mano Met de hand À la main		<b>Optional</b> Opcional Optional Opcional Opzionale Optie En option
	<b>Hex-Head Wrench</b> Llave de cabeza hexagonal Sechskantschlüssel Chave de cabeça sextavada Chiave esagonale Zeskantsleutel Clé à tête hexagonale		<b>Security Wrench</b> Llave de seguridad Sicherheitsschlüssel Chave de segurança Chiave di sicurezza Veiligheidssleutel Clé de sécurité

**TOOLS REQUIRED FOR INSTALLATION**

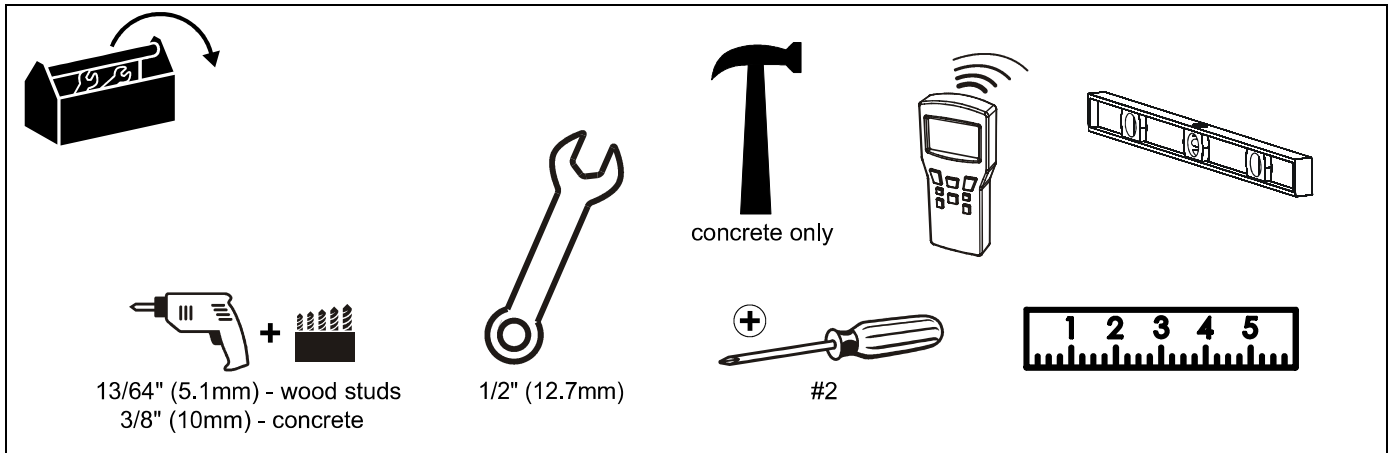

**PARTS**

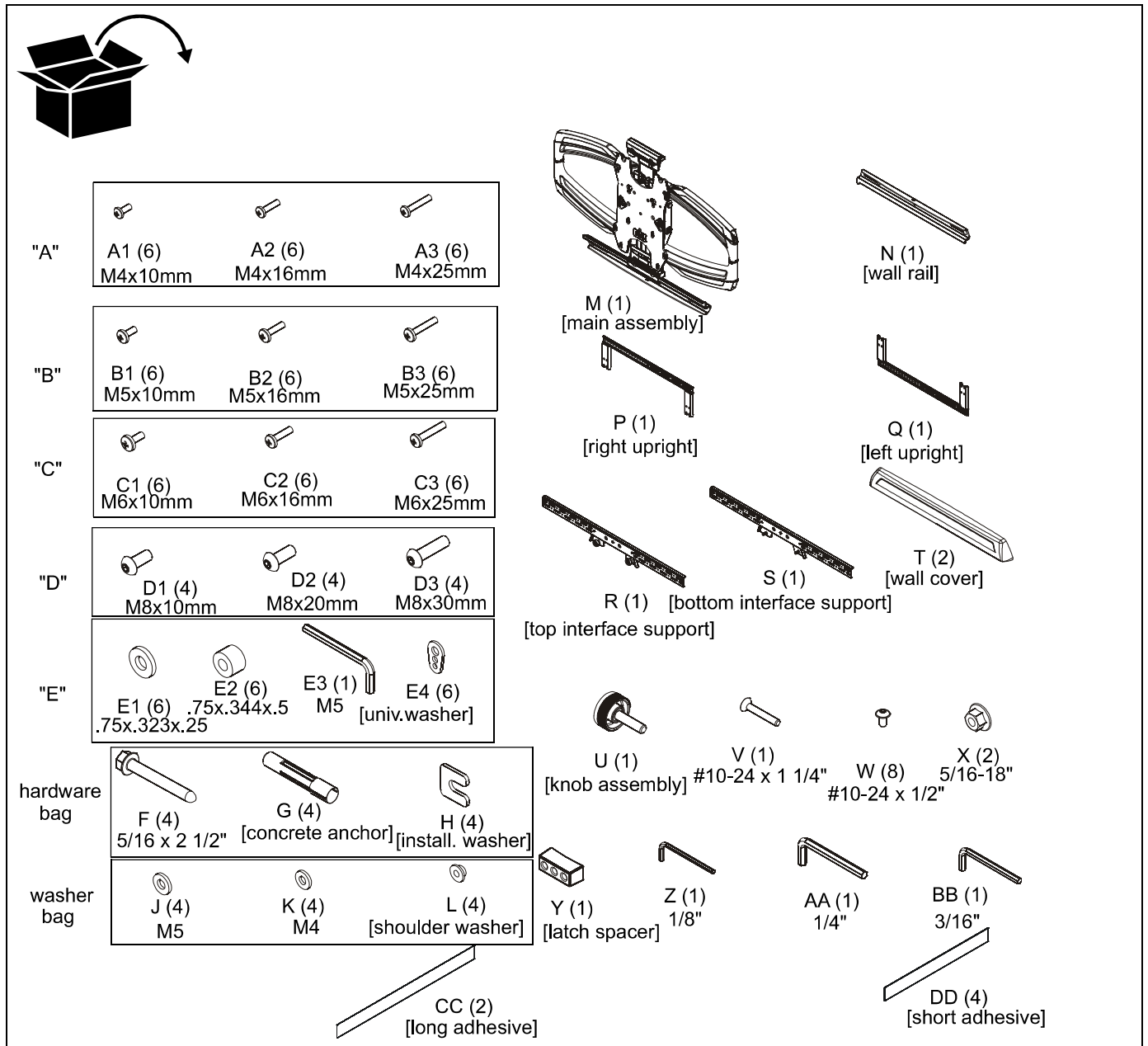

## Assembly And Installation

### Install Wall Plate to Wall - Wood Studs



**WARNING:** Failure to provide adequate structural strength for this component can result in serious personal injury or damage to equipment! It is the installer's responsibility to make sure the structure to which this component is attached can support five times the combined weight of all equipment. Reinforce the structure as required before installing the component. The wall to which the mount is being attached may have a maximum drywall thickness of 5/8" (1.6cm).

1. Determine mounting location. Use stud finder to locate 2" x 4" wood studs.
2. Measure 9 5/16" above desired center line and draw a horizontal line. (See Figure 1)

**NOTE:** Hold mount up to wall at desired mounting location if unsure about where the center line will be. The center line of the mount will coincide with the center line of the display. (See Figure 1)

**IMPORTANT ! :** Use a level to make sure wall rail (N) is level when mounted to the wall!

3. Drill two 13/64" holes at center of wood studs along the line drawn in the Step 2. (See Figure 1)

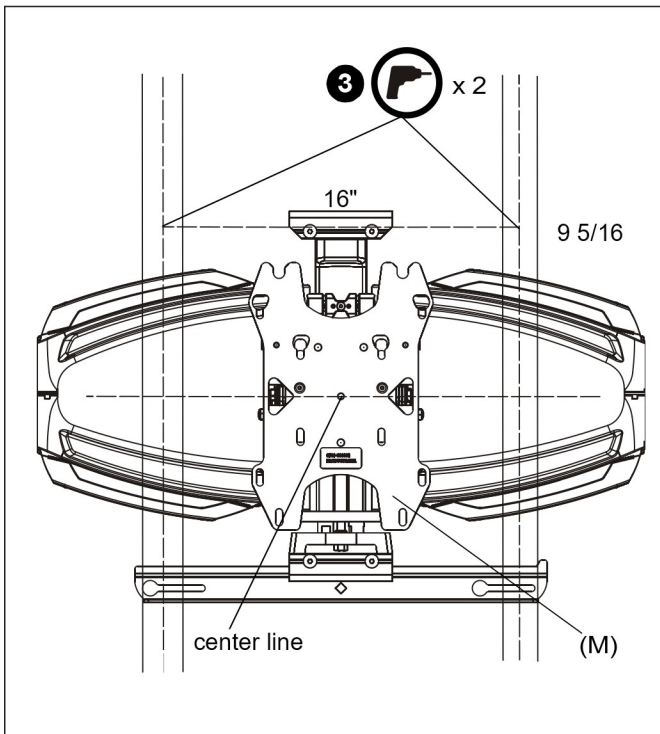

**Figure 1**

4. Loosely attach wall rail (N) to wall using two 5/16- 2 1/2" flange head lag screws (F). (See Figure 2)
5. Place two installation spacers (H) over two 5/16 x 2 1/2" flange head lag screws (F). (See Figure 2)
6. Tighten two screws (F) to secure upper wall rail (N) to wall. (See Figure 2)

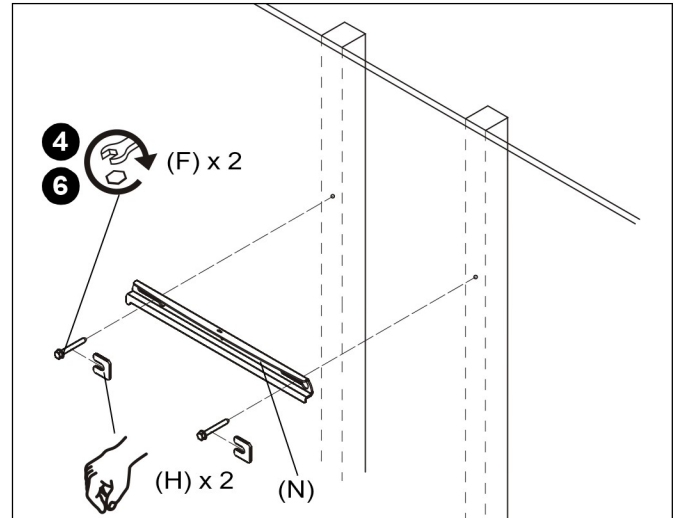

**Figure 2**

7. Slide main assembly (M) onto wall rail (N). (See Figure 3)

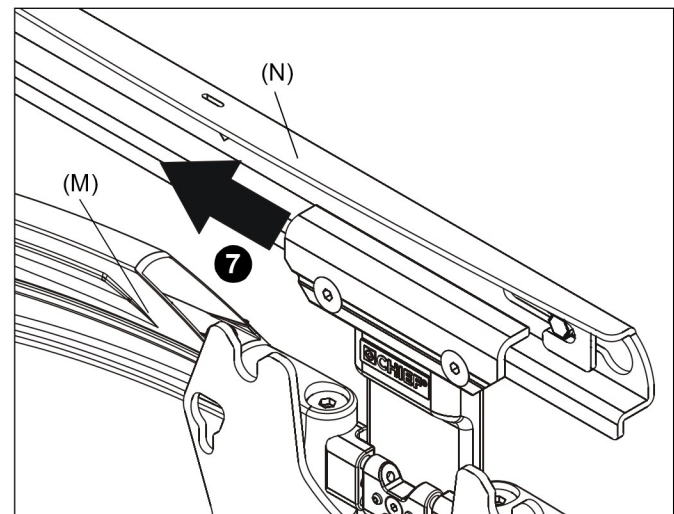

**Figure 3**

8. Center main assembly (M) over two studs.
9. Drill two 13/64" holes in center of wood studs at lower mounting holes. (See Figure 4)
10. Loosely install two 5/16 x 2 1/2" flange head lag screws (F). (See Figure 4)
11. Place two installation spacers (H) over two flange head lag screws (F). (See Figure 4)
12. Tighten two screws to secure main assembly (M) to wall. (See Figure 4)

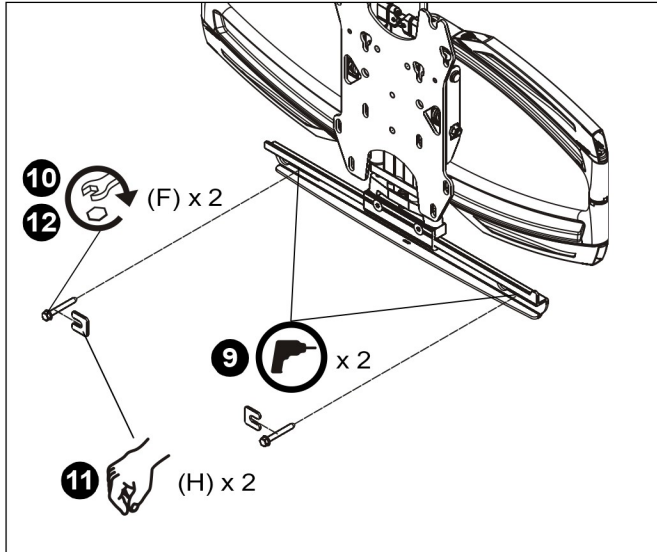

Figure 4

**WARNING:** DO NOT REMOVE SPACER AS SHOWN BELOW PRIOR TO INSTALLING THE LOWER TWO LAG SCREWS OR THE MOUNT WILL FALL OFF THE WALL WHEN THE SPACER IS REMOVED!

13. Loosen two flat head cap screws on upper carriage rail in order to loosen white spacer. (See Figure 5)
14. Remove white spacer from mount. (See Figure 5)
15. Tighten flat head cap screws. (See Figure 5)

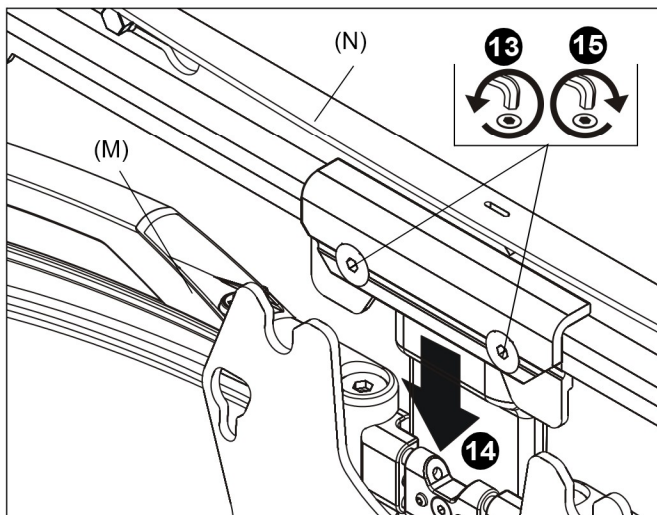

Figure 5

16. Proceed to Install Interface Bracket to Display section on page 9.

**Install Wall Plate to Wall - Hollow Concrete Block or Poured Concrete (Important!- Read warnings below for drywall restrictions!)**

**WARNING:** Failure to provide adequate structural strength for this component can result in serious personal injury or damage to equipment! It is the installer's responsibility to make sure the structure to which this component is attached can support five times the combined weight of all equipment. Reinforce the structure as required before installing the component.

**WARNING:** The wall to which the mount is being attached may have a maximum drywall thickness of 5/8" (1.6cm) if installing to hollow concrete block. If installing to poured concrete, the wall CANNOT have ANY drywall covering!

**WARNING:** INSTALLING THE TS525TU INTO UNDERRATED OR DAMAGED CONCRETE CAN LEAD TO SERIOUS INJURY OR DAMAGE TO PRODUCT! When installing into concrete, only install the TS525TU into concrete at least 8" in depth or into 8"x8"x16" concrete blocks! Never install the TS525TU into cracked, chipped or flaking concrete.

1. Determine mounting location.
2. Measure 9 5/16" above desired center line and draw a horizontal line. (See Figure 6)

**NOTE:** Hold mount up to wall at desired mounting location if unsure about where the center line will be. The center line of the mount will coincide with the center line of the display. (See Figure 6)

**IMPORTANT ! :** Use a level to make sure wall rail (N) is level when mounted to the wall!

3. Drill two 3/8" holes 16" apart and along the line drawn in the Step 2. (See Figure 6)

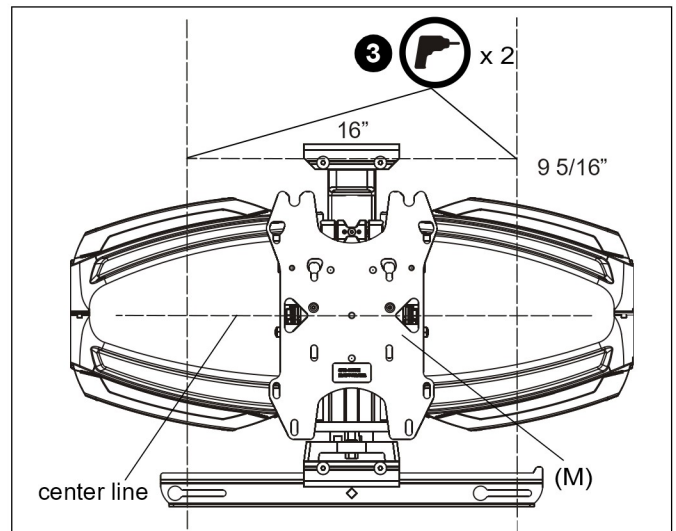
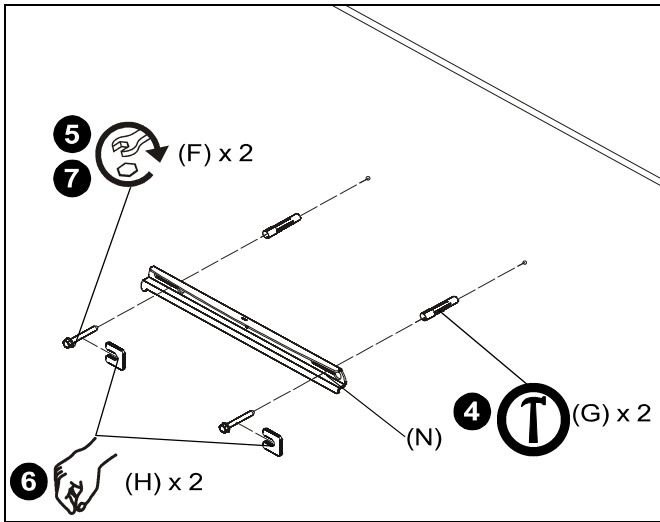

Figure 6

4. Install two concrete anchors (G) into two drilled holes. (See Figure 7)
5. Loosely attach wall rail (N) to wall by installing two 5/16- 2 1/2 flange head lag screws (F) into concrete anchors (G). (See Figure 7)

**IMPORTANT !** : Use a level to make sure wall rail (N) is level when mounted to the wall!

6. Place two installation spacers (H) over two 5/16 x 2 1/2" flange head lag screws (F). (See Figure 7)
7. Tighten two screws to secure upper wall rail (N) to wall. (See Figure 7)



**Figure 7**

8. Slide main assembly (M) onto wall rail (N). (See Figure 8)
9. Center main assembly (M) over wall rail (N). (See Figure 8)
10. Mark two holes at lower mounting holes. (See Figure 8)
11. Slide main assembly (M) off wall rail (N). (See Figure 8)
12. Drill two 3/8" holes at marked locations. (See Figure 8)
13. Install two concrete anchors (G) into drilled holes. (See Figure 8)

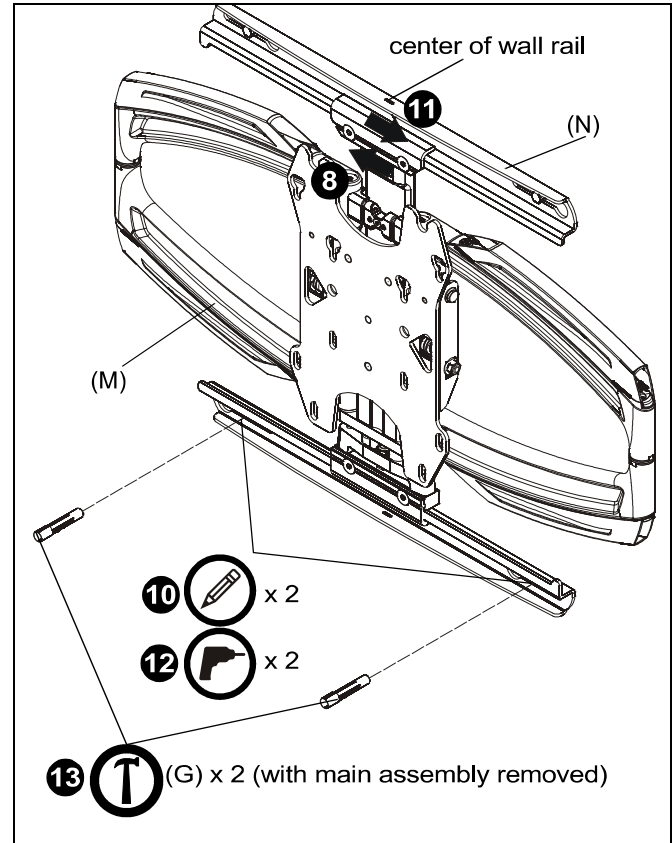

**Figure 8**

14. Slide main assembly (M) back onto wall rail (N). (See Figure 9)

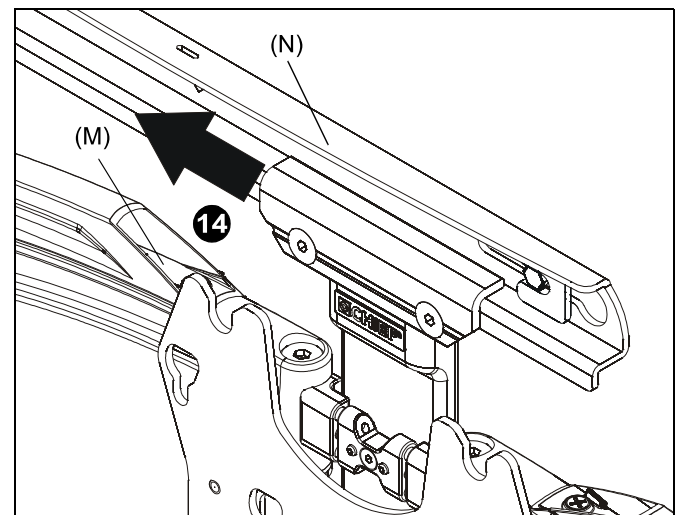

**Figure 9**

15. Loosely install two 5/16 x 2 1/2" flange head lag screws (F) through lower wall rail on main assembly and into concrete anchors. (See Figure 10)
16. Place two installation spacers (H) over two flange head lag screws (F). (See Figure 10)
17. Tighten two screws (F) to secure main assembly (M) to wall. (See Figure 10)

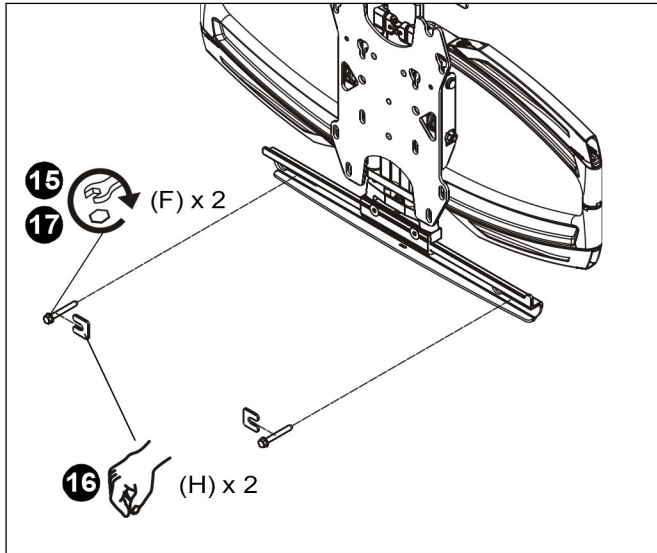

Figure 10



**WARNING:** DO NOT REMOVE SPACER AS SHOWN BELOW PRIOR TO INSTALLING THE LOWER TWO LAG SCREWS OR THE MOUNT WILL FALL OFF THE WALL WHEN THE SPACER IS REMOVED!

18. Loosen two flat head cap screws on upper carriage rail in order to loosen white spacer. (See Figure 11)
19. Remove white spacer from mount. (See Figure 11)
20. Tighten flat head cap screws. (See Figure 11)

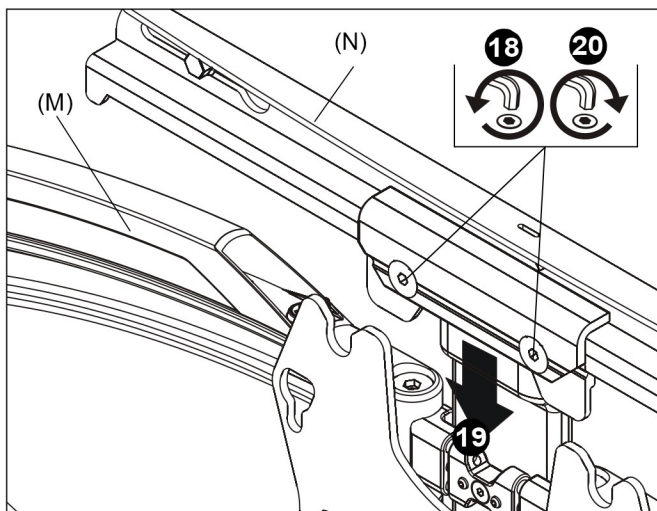

Figure 11

## Install Interface Bracket to Display

**IMPORTANT !** : If the displays hole pattern size is 100mm x100mm, 200mm x 200mm or 100mm x 200mm, the display can be mounted directly to the faceplate and the interface bracket **DOES NOT** need to be installed! Proceed to Install Display section.

1. Lay display face down on protective surface.



**CAUTION:** Using screws of improper diameter may damage your display! Proper screws will easily thread into display mounting holes.

2. Select screw *diameter* by examining hardware (A-D) (4mm, 5mm, 6mm or 8mm) and comparing with mounting holes on display. (See Figure 12)
3. Select spacers: (See Figure 12)
  - If mounting holes are not recessed and both uprights (P and Q) can lay flat against display, then no spacers are required.
  - If mounting holes are recessed, or if protrusions prevent uprights (P and Q) from laying flat, then spacers (E1 or E2) must be used.



**CAUTION:** Using screws of improper length may damage your display! Proper screws will have adequate thread engagement without contacting bottom of display mounting holes.

4. Select screw *length*: (See Figure 12)
    - Using your hand, insert **SHORTEST** length screw of selected diameter (A1, B1, C1 or D1) through universal washer (E4), uprights (P or Q), selected spacer (E1 or E2, if required), into display mounting hole. Do **NOT** thread screw into hole at this time.
- NOTE:** Universal washers (E4) are not needed if using M8 button head cap screws (D).
- Proper screw length requires base of screw head to protrude above flat washer a *distance equal to or greater than the screw diameter*. If screw length is inadequate, select longer screw. Select *shortest* screw which will protrude the required distance.

5. Place uprights (P and Q) on display, ensuring: (See Figure 13)
  - Center of uprights (P and Q) are as close to the center of the back of display as possible after being installed. Center of bracket is indicated by the diamond-shaped hole.

**NOTE:** If installing to a display with a narrow hole mounting pattern (less than 400mm wide), reverse uprights (P and Q) so that the upright legs do not overlap onto each other. (See Figure 13)

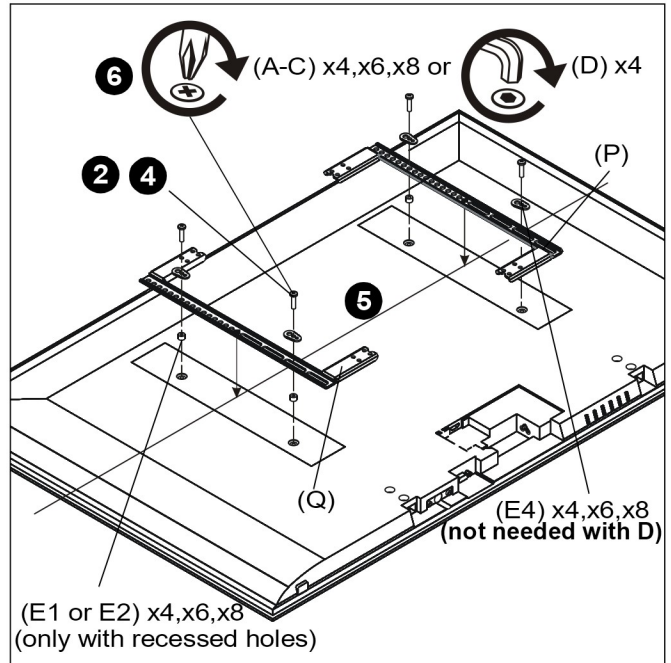

Figure 12

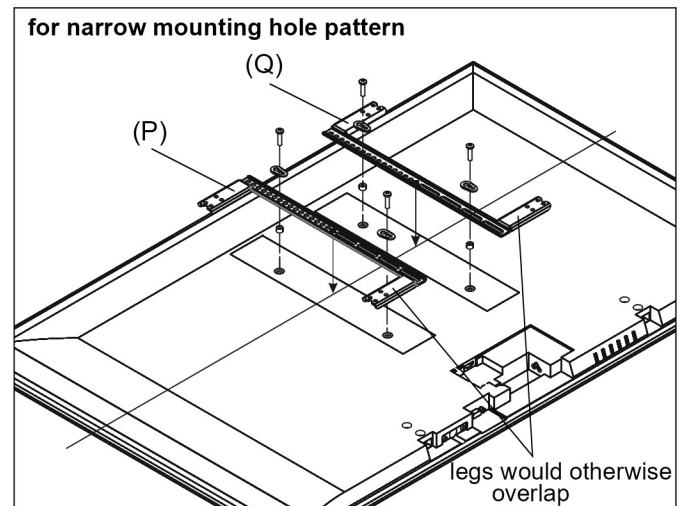

Figure 13

6. Using Phillips screwdriver, carefully install selected screws through universal washers (E4, if required), uprights (P and Q), and spacers (E1 or E2, if required), into display. (See Figure 12)
7. Tighten all screws. Ensure all applicable display mounting holes (4, 6, or 8) are used.

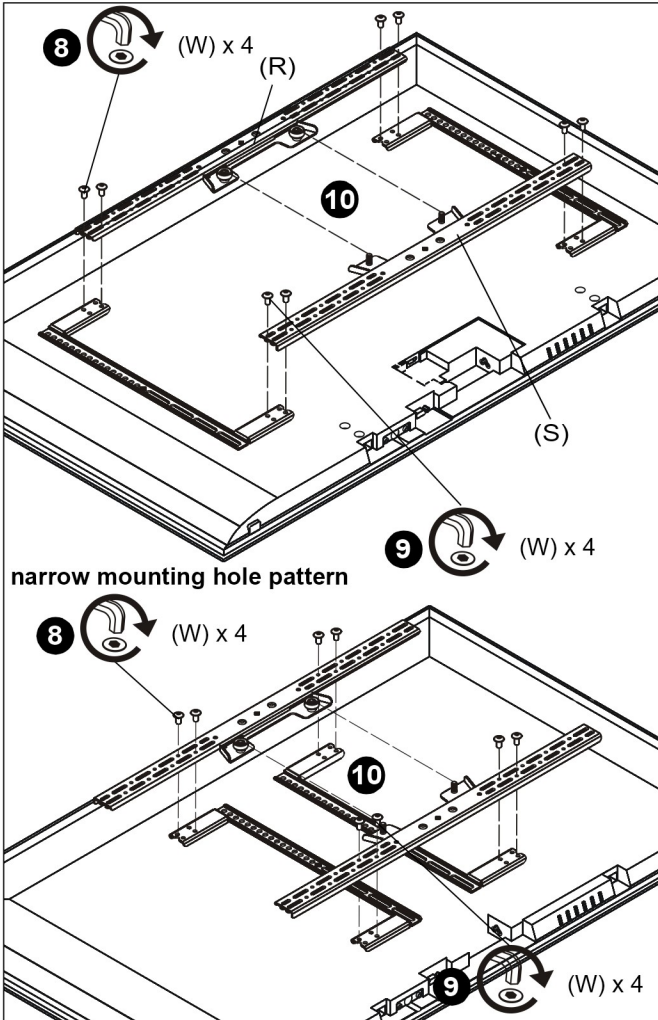

Figure 14

8. Connect top interface support (R) to uprights (P and Q) using four #10-24 x 1/2" button head cap screws (W). (See Figure 14)

**NOTE:** If possible install screws diagonally across from each other in order to provide maximum support in Steps 8 and 9.

9. Connect bottom interface support (S) to uprights (P and Q) using four #10-24 x 1/2" button head cap screws (W). (See Figure 14)

10. When connecting bottom interface support (S) to uprights, make sure that it is aligned vertically with top interface support (R). (See Figure 14)

### Installing Display

#### Using Interface Bracket



**WARNING:** Exceeding the weight capacity can result in serious personal injury or damage to equipment! It is the installer's responsibility to make sure the combined weight of all components attached does not exceed 125 lbs (56.7 kg). Use with products heavier than the maximum weight indicated may result in collapse of the mount and its accessories causing possible injury.



**WARNING:** Display may be very heavy! Ensure display can be safely lifted and maneuvered as required to install on wall plate. Failure to take adequate precautions can result in serious personal injury or damage to equipment!

1. Hang interface bracket and display to faceplate by placing two mounting buttons on top interface support (R) over two teardrop grooves on top of faceplate. (See Figure 15)
2. Secure interface bracket and display to faceplate by installing two 5/16-18" flange nuts (X) onto screws on lower interface support (S). (See Figure 15)

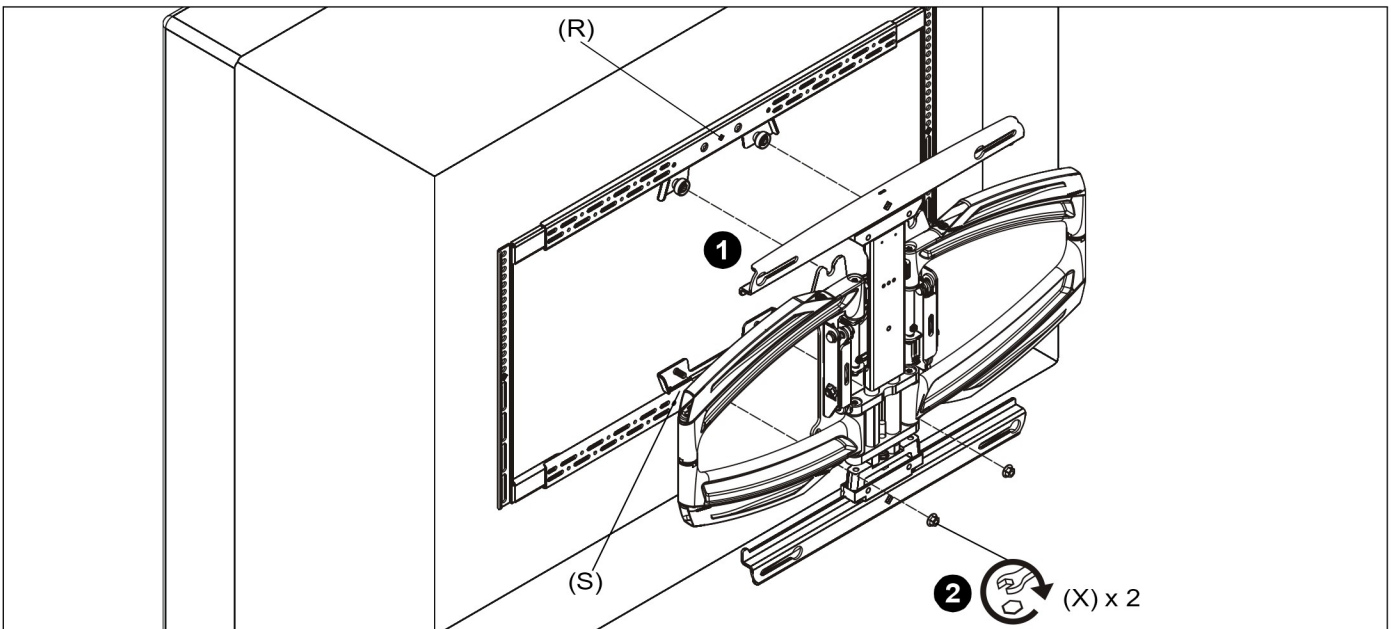

Figure 15

**Installing Display Without Interface Bracket  
(100x100, 200x200 or 100x200)**



**CAUTION:** Using screws of improper diameter may damage your display! Proper screws will easily thread into display mounting holes.

1. Select screw *diameter* by examining hardware (A-D) (4mm, 5mm, 6mm or 8mm) and comparing with mounting holes on display.



**CAUTION:** Using screws of improper length may damage your display! Proper screws will have adequate thread engagement without contacting bottom of display mounting holes.

2. Select screw *length*:
  - Using your hand, insert **SHORTEST** length screw of selected diameter (A1, B1, C1 or D1) into display mounting hole. Do **NOT** thread screw into hole at this time.
3. Install two selected screws (A-D) into upper two holes on back of display. (See Figure 16)

**IMPORTANT ! :** If using M4 or M5 screws (A or B), washer hardware (J, K and L) must be used to ensure tight fit into the faceplate holes! For M4 screws (A), use M4 washer (K) and shoulder washer (L). For M5 screws (B), use M5 washer (J) and shoulder washer (L). (See Figure 16)

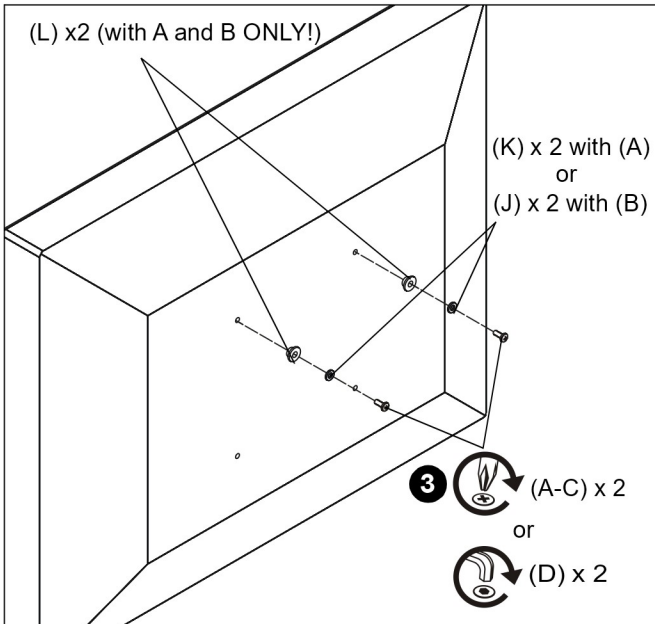

**Figure 16**

4. Hang display by two screws onto faceplate through either inner or outer teardrop mounting holes. (200x200 mounting pattern shown) (See Figure 17)
5. Secure display to faceplate by installing two selected screws (A-D) through washer hardware (J,K, and L) for M4 (A) and M5 (B) screws only, lower holes on faceplate and into lower two holes on display. (See Figure 17)

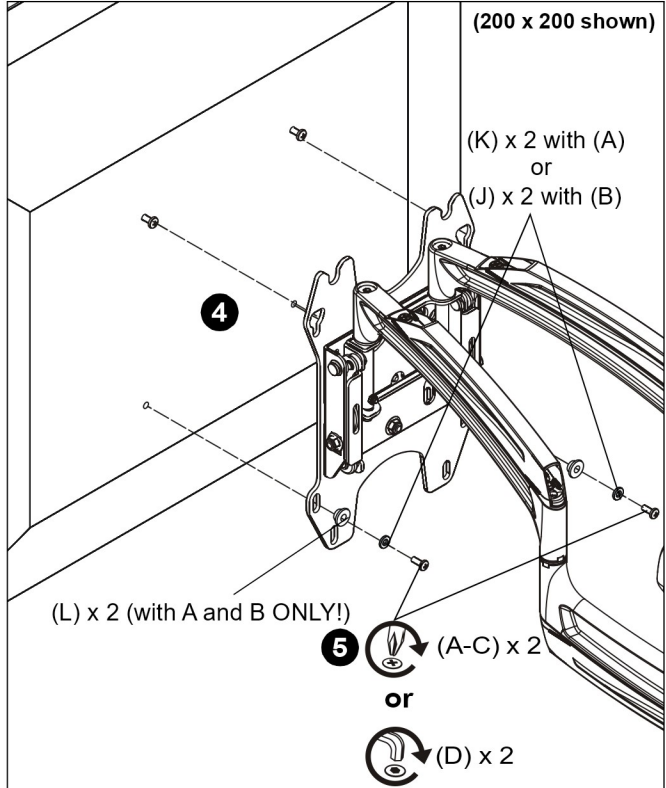

**Figure 17**

**Wall Cover Installation**



**CAUTION:** Wall covers are fragile and may be damaged or broken if installed with excessive force! Use caution when installing and removing wall covers.

1. Turn wall cover (T) outward to allow outside of covers to wrap around wall rail. (See Figure 18)
2. Place wall cover (T) over wall rail. (See Figure 18)

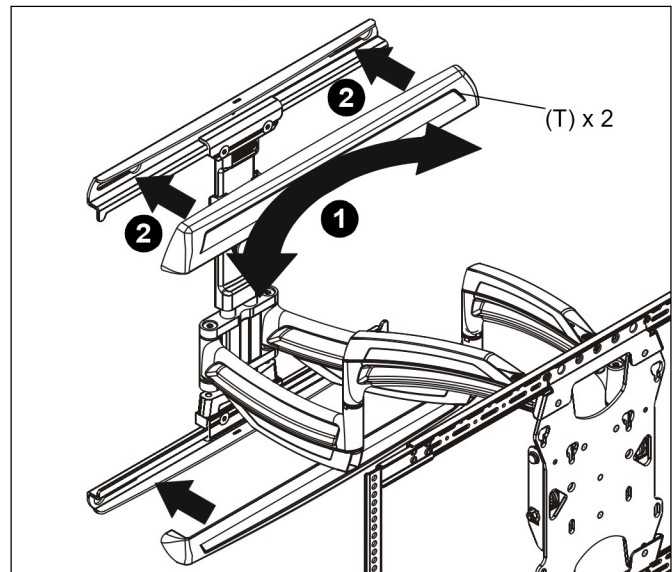

**Figure 18**

### Cable Management

1. Make all cable connections to display.
2. Open cable management covers on upper and lower swing arms. (See Figure 19)
3. Route cables on top of upper arm. (See Figure 19)
4. (Optional) Use cable ties (not included) to secure cables to upper arms by threading ties around cable and through cable tie holes on arms. (See Figure 19)
5. Close upper cable management cover. (See Figure 19)
6. Route cables under lower portion of swing arm. (See Figure 19)
7. (Optional) Use cable ties (not included) to secure cables to lower arms by threading ties around cable and through cable tie holes on arms. (See Figure 19)
8. Close lower cable management cover. (See Figure 19)

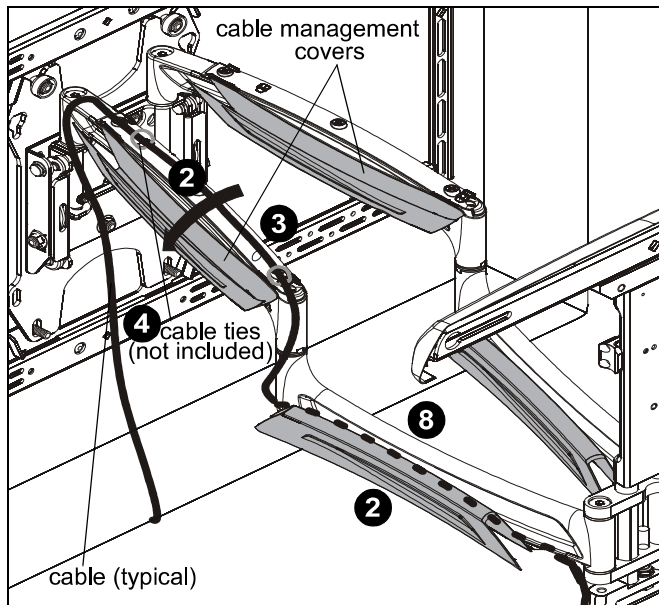

Figure 19

### Creating Space (Optional)

In order to create more space between display and mount, spacers may be added.

1. Extend swing arms in order to gain access to the center support.
2. Remove flat hex-head screw holding latch to center support. (See Figure 20)
3. Place latch spacer (Y) behind latch and line with holes on center support. (See Figure 20)
4. Install #10-24 x 1 1/4" flat hex-head screw (V) through latch and latch spacer (Y) and into holes on center support. (See Figure 20)

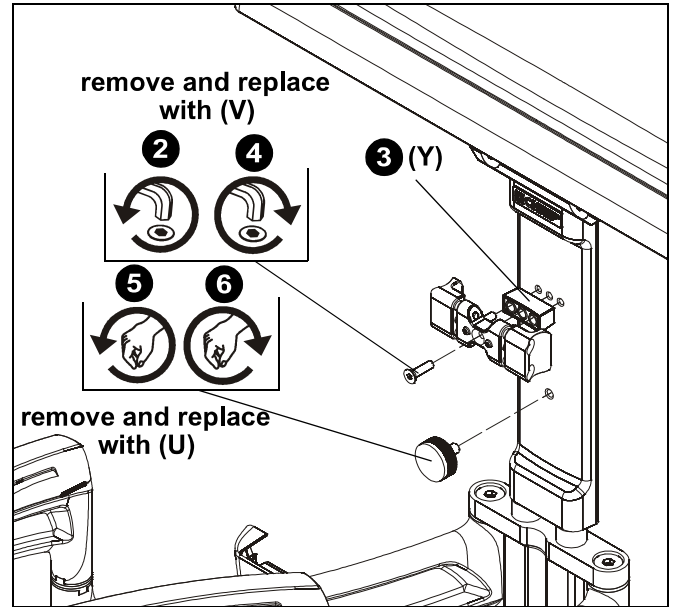

Figure 20

5. Remove 1/2" knob assembly installed on center support. (See Figure 20)
6. Replace 1/2" knob assembly with 1" knob assembly (U). (See Figure 20)

### Height Adjustment

1. Extend swing arms in order to gain access to the center support.
2. Adjust height adjustment wrench to raise or lower mount to desired height. Turn counter-clockwise to raise mount and clockwise to lower mount. (See Figure 21)

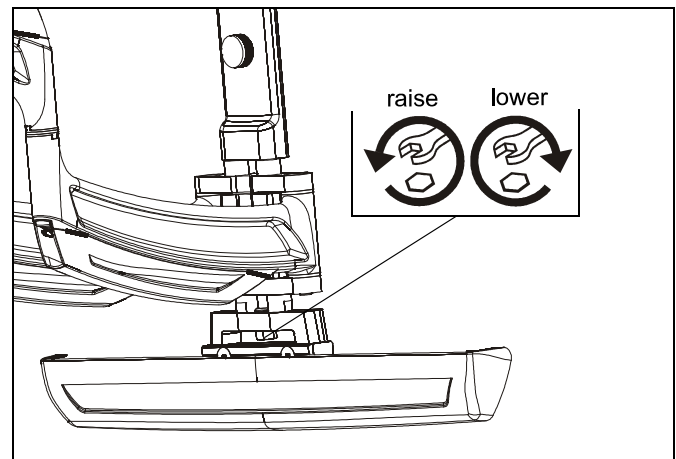

Figure 21