

BCS250 CEILING PASSIVE SPEAKER



The BCS250 is a premium passive commercial-grade in-ceiling speaker, specifically designed for both low impedance and constant voltage applications in new build or retrofit scenarios. Its discreet design seamlessly blends with any interior design or décor, making it an ideal choice. With a high-performance build, including a UL 2043 plenum rating, the BCS250 is fully certified for commercial installation. Additionally, the optional pendant kit offers the flexibility to suspend the BCS250 from the ceiling at a lower height if there are no suitable mounting options available at the typical height.

The BCS250 are passive in-ceiling speakers that make for a great complement to the B170S Networked Streaming Stereo Amplifier, offering both low impedance and constant voltage options (70/100V).

Low impedance option delivers better audio quality overall, while the constant voltage option allows for daisy chained speaker configurations.

The BCS250 speakers are ideal for a wide range of applications, whether you're retrofitting an existing system or building a new one. Moreover, their user-friendly design makes it effortless to replace or update an existing system, for the ultimate installation flexibility. The BCS250 in-ceiling speakers are incredibly discreet, making them ideal for environments where wall space is limited, such as small cafes and shops.

With a slim profile requiring just 5 inches of depth, these speakers can be seamlessly installed, especially in areas where walls are already adorned with various objects.

FEATURES

- Tuned Crossover for uniform frequency response over the coverage area
- High Dispersion Coverage
- Snap –fit magnetic grille
- Long travel dog-ear mount system
- Quick connect Phoenix connector
- Low-saturation and low-loss 70/100V transformers with 8 ohm bypass
- UL2043 and UL1480A Safety Certification
- Integration with local network content storage
- Available in White with Black Grille accessory option
- Complete EASE, CLF information available on-line

ARCHITECTS & ENGINEERS SPECIFICATION

Speaker must be low profile at 127mm (5 inches) or less in depth. Flush mounted using dog mount system. Additionally, the paintable grilles must have a magnetic attachment system. Must be UL2043, UL1480A Certified.

Unit must be able to be transformed into a pendant format via accessory kit

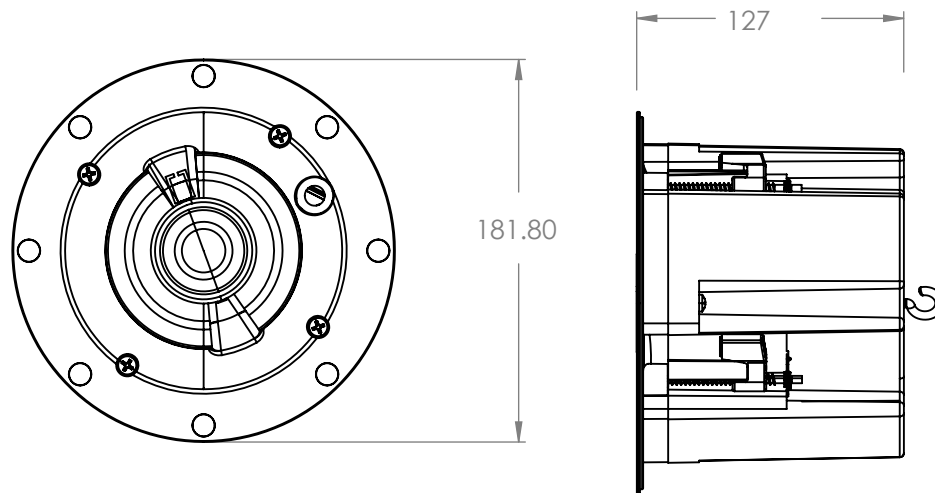

SPECIFICATIONS

Speakers	1 X 89mm(3.5"), Woofer 1X 25mm (1"), Tweeter
Frequency Response	-10db 65 Hz -20kHz
Rated Power	80 Watts
Rated Maximum Spl	105db@i meter average, 110 db peak
Sensitivity	@1 W, 1m:84db
Coverage	150 degrees conical coverage
TRANSFORMER TAPS	70V = 3,5,7,15,30,8ohms 100 V = 7,15,30,NC,8ohms
INPUT CONNECTOR TYPE	Phoenix connector , Parallel output
Operating Environment	Designed for indoor use
OPERATING TEMPERATURE RANGE	-20 to 50 C (-4 to 122 F)
Cutout Dimension	152mm (6") diameter
Net Weight	2.2kg (5 lb)
Dimensions	182mm (7.1") DIA x 126mm(4.9") H
Packaging Dimensions	230x197x197 mm (9x7.7x7.7 in)
Included Accessories	Phoenix connector, white grille
Optional Accessories	Black Grille, Square White Grille, Square Black Grille, Pendant kit-White, Pendant Kit -Black
Safety	UL2043, UL1480A