



SBMS

Square Beam Mount Speaker



**SBMS
(Front)**

Specifications

Power Rating	25 Watts (Transformer Limited)
70.7V Taps	.25, .5, 1, 2, 4
Frequency Response	85Hz – 20kHz (±3dB)
Sensitivity (1W/1M)	92dB
Woofer	8" Dual Cone
Woofer Magnet Weight	10oz. (264g)
Length	11 ⁹ / ₁₆ " (294mm)
Width	11 ⁵ / ₈ " (294mm)
Height	5 ⁵ / ₈ " (143mm)
Enclosure Volume	712 in ³
Weight	9.5 lbs (4.31kg.)

Architect and Engineer Specifications

The loudspeaker, transformer, baffle, and enclosure assembly shall be Atlas Sound's clamp-mounting Model SBMS. The loudspeaker shall be a 25 Watts 8" (203mm) diameter, dual cone type with frequency response of 50Hz – 18kHz (±10dB). Loudspeaker shall include a factory-wired 25V/70.7V transformer with power taps of .25, .5, 1, 2, and 4 Watts. Assembly shall be shipped complete with a square baffle and matching CRS constructed enclosure. Enclosures shall be equipped with two, screw-down adjustable clamps for mounting. Loudspeakers shall have lead wires extending out of the enclosure through a wire-securing cable clamp for expedited connection. Assembly shall be finished in white. Assembly weight shall be 9.5lbs (4.3kg).

Features

- Easy-To-Install Loudspeaker Package Includes Provisions for Fast Clamp-Mount Installation to I-Beams and Girders
- Package Includes an 8" Dual-Cone Loudspeaker with a Pre-Mounted Transformer, Baffle and Enclosure Equipped with Clamp Mounts
- Convenient Lead Wire Extensions Assure Expedited Field Connection
- Durable White Powder Coat Finish

General Information

The SBMS is ideal for "big box" retail stores whose special design calls for an open beam ceiling. Since the goals are to get customers to pay attention to the announcements of specials and the employees to respond to general paging — intelligibility is a top design goal. The high efficiency of the specially designed 8" speaker included in the SBMS package fills this requirement. Atlas gave the SBMS a square design, which blends in with the overall aesthetic of an open beam ceiling.

The SBMS is infinitely flexible, complying with a variety of conduit requirements. Integral knockouts facilitate 1/2" and 3/4" conduit where required by code while integral "romex" style connector simplifies installation for applications where conduit is not required at all. The SBMS also includes a 25V/70.7V internal transformer and is finished in neutral white epoxy for simplified stocking and ordering.

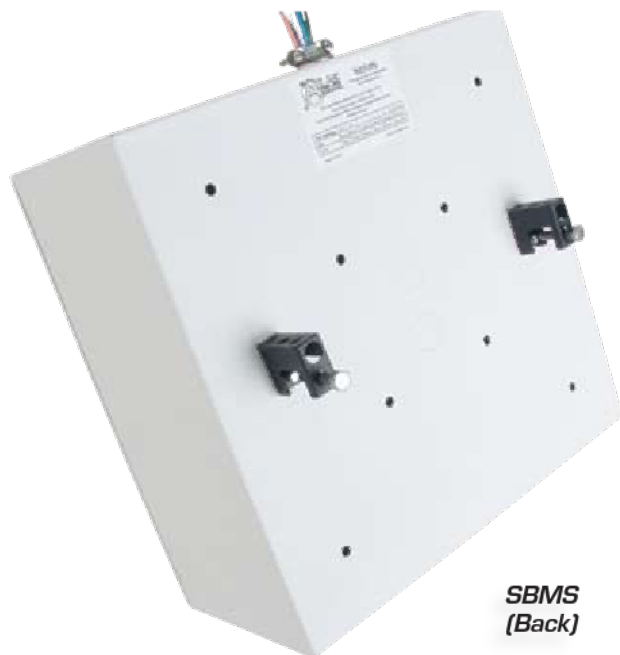

**SBMS
(Back)**

©2011 Atlas Sound L.P. All rights reserved. Atlas Sound and Strategy Series are trademarks of Atlas Sound L.P. All other trademarks are the property of their respective owners. ATS001310 RevC 6/11

SMBS Dimensions

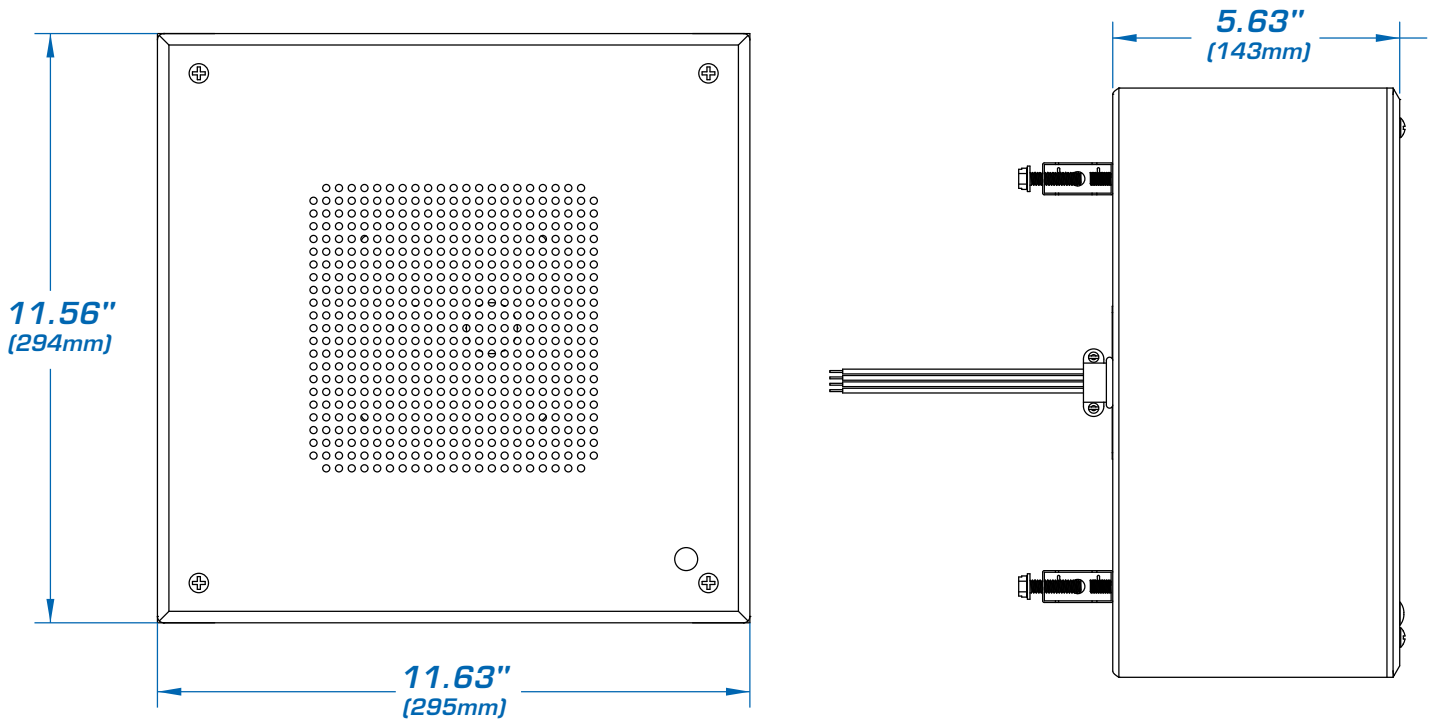

©2011 Atlas Sound L.P. All rights reserved. Atlas Sound and Strategy Series are trademarks of Atlas Sound L.P. All other trademarks are the property of their respective owners. AT5001310 RevC 6/11