



AS-6T

SURFACE MOUNT LOUDSPEAKER

TECHNICAL DATA SHEET

PRODUCT SUMMARY

The AtlasIED AS-6T is a two-way compact Surface-Mount weather resistant loudspeaker designed for a wide variety of sound reinforcement applications where durability, modern, understated aesthetics, and outstanding sonic performance are prerequisites.

Featuring a high excursion 6" polypropylene woofer, seamlessly transitioning to a 1.25" silk dome, ferrofluid cooled high frequency driver, the AS-6T delivers a consistent and accurate broadband frequency response, both on and off axis.

Available in textured black or white, the outstandingly durable and scuff resistant, high impact ABS enclosure with UV inhibitor is weather resistant (IP55), for consistent performance in adverse conditions, both indoors and out.

Safe and effective Installation of the AS-6T is made simple by way of the included slip free yoke mount, optional universal mount, or compatibility with 3rd party VESA mounts.

Equipped with a low insertion loss 60W transformer for 70V or 100V distributed applications, wattage tap selection and low impedance bypass is easily configurable via a rear mounted slide selector switch with security cover.

The AS-6T has been sonically matched with the wider range of AS Series models, this allows consistency in installations where there is a mix of products used.

For the most discerning designers and integrators, a complete suite of EASE™ (including compatibility with EASE Focus), CF2, 3D CAD, and BIM/Revit families are available for download at AtlasIED.com.

KEY FEATURES

- Minimalistic and clean industrial design for sensitive architectural constraints
- Effective coverage for systems with space limitations
- Extremely consistent off axis performance
- Ultra-low insertion loss 60W transformer for dynamic performance in distributed systems
- High impact ABS enclosure with UV inhibitor
- IP55 rated
- Slip-Free yoke mount supplied. Optional pan and tilt bracket. Compatible with VESA™ mounts
- Advanced tunings available via AtlasIED Atmosphere DSP platform

APPLICATIONS

- Bars & Restaurants
- Hotels, Casinos & Cruise Ships
- Retail
- Houses of Worship
- Education
- Transportation
- Corporate & Business
- Museums & Courthouses
- Healthcare
- Fill and spot coverage for large systems



AS-6T

SURFACE MOUNT LOUDSPEAKER



TECHNICAL DATA SHEET

AUDIO SPECIFICATIONS / PERFORMANCE

SYSTEM	AS-6T
Type	Two-Way, Full Range, Surface Mount Loudspeaker
Frequency Range (-10dB) ¹	55Hz ⁶ -20kHz
Frequency Response (+/- 3dB) ¹	74Hz-20kHz
System Sensitivity (1W @ 1m) ²	88dB
Nominal Coverage Angle (HxV -6dB)	110° x 90°
POWER HANDLING³	
Average	150W
Programme	300W
Peak	600W
Recommended Amplifier Power	300W @ 8 Ohms
Nominal Impedance	8 Ohms (Min 7.5 Ohms)
RATED MAXIMUM SPL⁴	
Average	110dB
Peak	116dB
With Max. Transformer Tap - Average	106dB
Transformer Taps- via slide selector switch	60W, 30W, 15W, 7.5W,(3.8W 70V) & Low Z operation
Directivity Index (dB) ⁵	6.6
TRANSDUCERS	
Low Frequency	6" (150mm) Polypropylene, Butyl Rubber surround
High Frequency	1.25" (32mm), Silk Dome, Ferrofluid Cooled, PPT Protection
PHYSICAL	
Enclosure	High Impact ABS UL-V0
Grille Material	Aluminum, Powder Coated
Connectors	Euroblock with screw connections and loop output
Safety Agency Rating	CE
Ingress Protection	IP55
Operating Temperature	-40°F to 140°F (-40° C to 60° C)
Environmental Testing	Conforms to MIL-STD-810 for salt spray & humidity
Included Accessories	Slip Free U-Bracket
Optional Accessories	Pan & Tilt Bracket
Packed Quantity	2
Product Dimensions (HxWxD)	13.9" x 7.73" x 8.17" (353.1mm x 196.3mm x 207.5mm)
Shipping Dimensions (HxWxD)	22.4" x 20.1" x 10.6" (57cm x 51cm x 27cm)
Net Weight - (per unit)	13.0 lbs (5.9kg)
Shipping Weight	16.87kg (37.19 lbs)

Notes:

1 - Average over stated bandwidth, full space

2 - Unweighted pink noise input, measured at 1 meter on axis

3 - Long term power handling capacity as defined in EIA - 426B test

4 - Calculated from rated noise power and sensitivity

5 - 1k-10kHz average

6 - Recommended High-Pass (24dB/Oct)

A full range of measurements, performance data, Ease™ and CLF Data can be downloaded from www.atlasied.com.

AS-6T

SURFACE MOUNT LOUDSPEAKER



TECHNICAL DATA SHEET

PERFORMANCE MEASUREMENTS

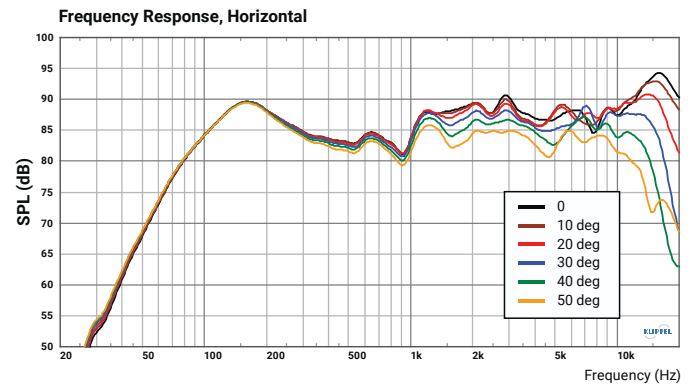
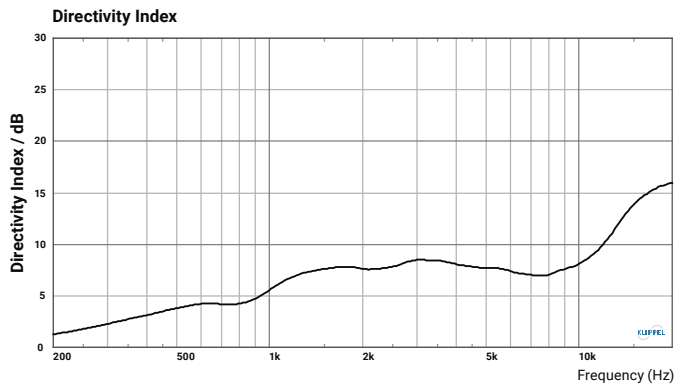
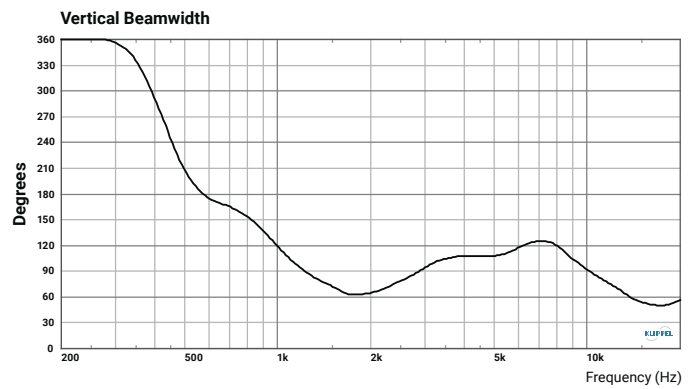
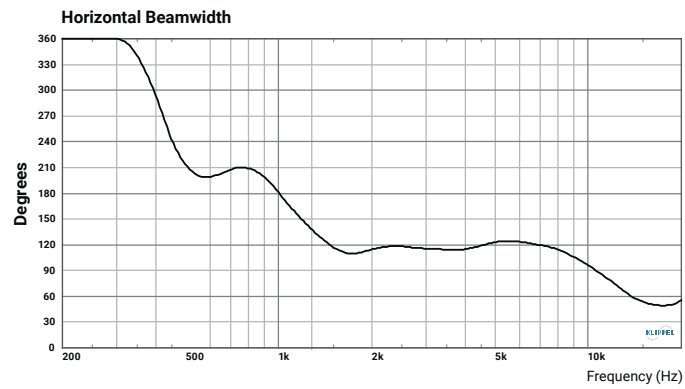
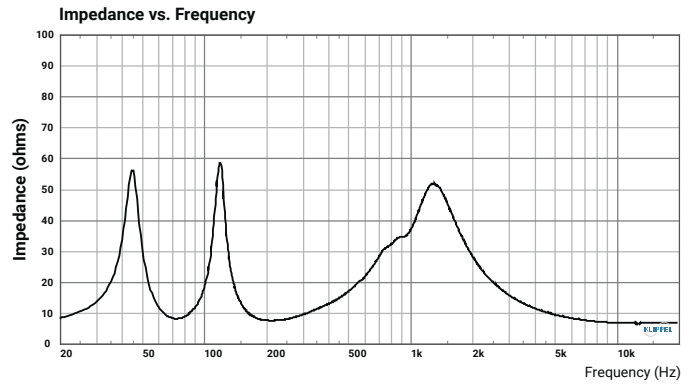
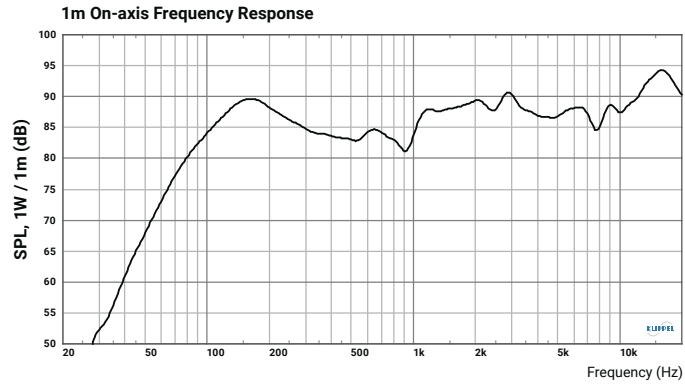

AS-6T

SURFACE MOUNT LOUDSPEAKER



TECHNICAL DATA SHEET

PERFORMANCE MEASUREMENTS

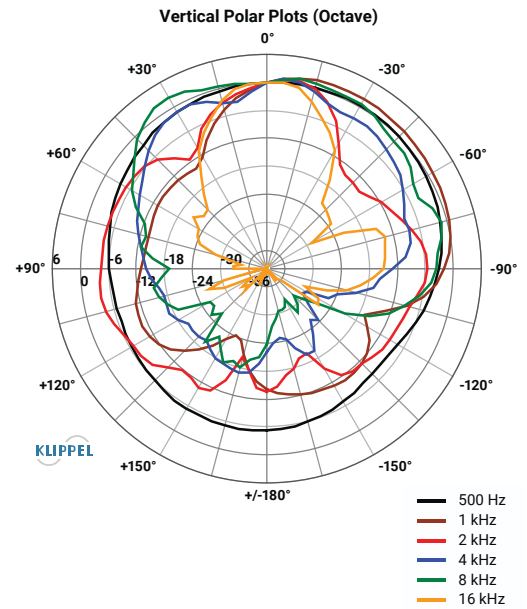
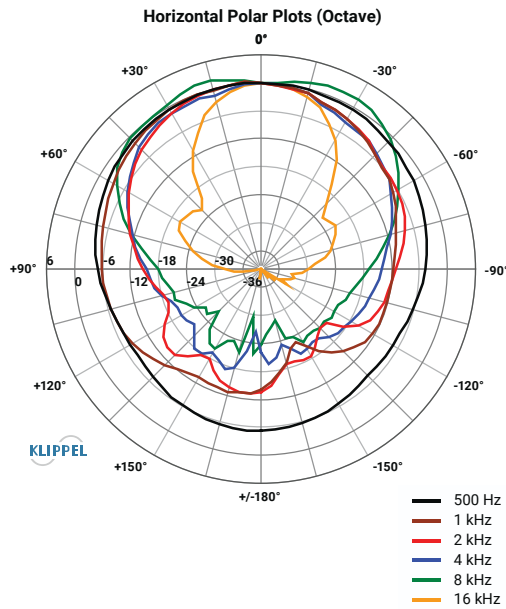
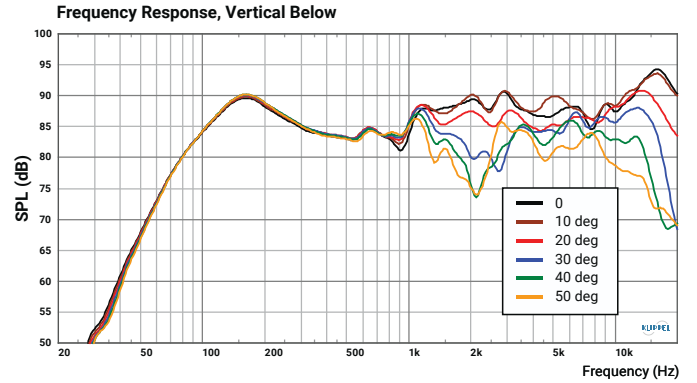
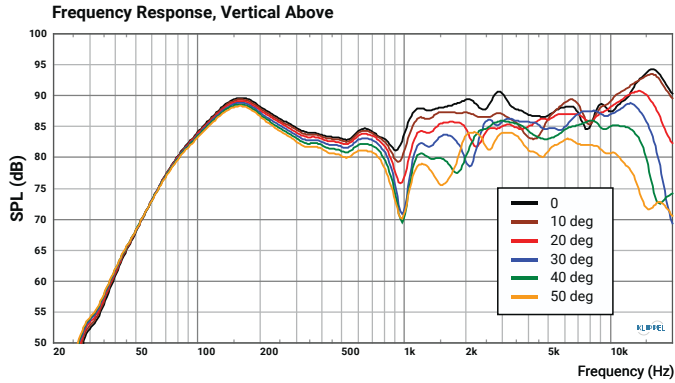

AS-6T

SURFACE MOUNT LOUDSPEAKER



TECHNICAL DATA SHEET

DIMENSIONAL DRAWINGS

PRODUCT DIMENSIONS

Without Bracket

Height	10.9" (277mm)
Width	7.73" (196mm)
Depth	8.17" (207mm)

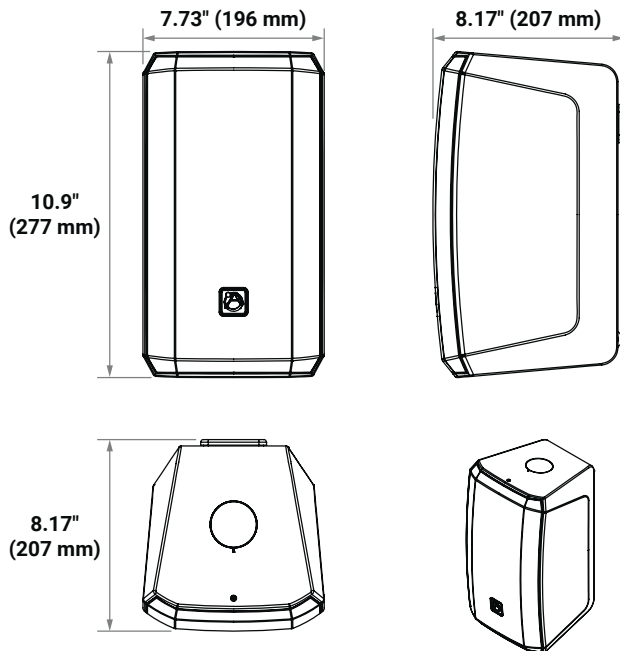

PRODUCT DIMENSIONS

With Bracket

Height	14" (356mm)
Width	7.73" (196mm)
Depth	9" (230mm)

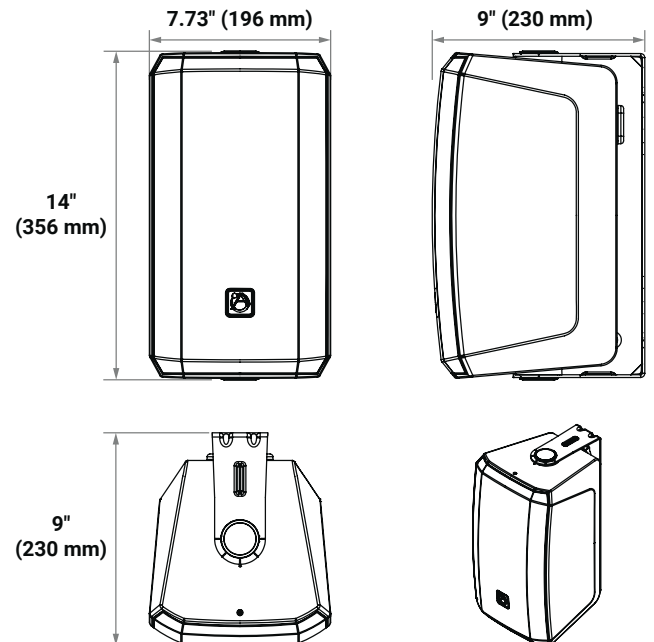

AS-6T

SURFACE MOUNT LOUDSPEAKER



TECHNICAL DATA SHEET

ARCHITECT AND ENGINEER SPECS

The loudspeaker shall be of a two-way surface-mount design with an internal passive crossover and a 60W low insertion loss 70/100V transformer for use in constant voltage distributed lines. A 6-inch Polypropylene woofer with butyl rubber surround and 1.25-inch silk dome tweeter with PPT protection shall be housed in a proprietary injection molded ABS, UV fade resistant enclosure. The enclosure shall exceed IEC60529 IP-55 ratings for dust and splash resistance, and Mil STD 810G for salt and humidity. Incorporated is a sealed input panel cover, and powder-coated aluminum grille. The loudspeaker color shall be either RAL 9016 (white) or RAL (9017) black. The unit shall ship with a slip free u-bracket that is powder coated in the same color as the enclosure. The loudspeaker shall have an optional knurled ball-joint pan and tilt mounting system with a quick attach/detach mechanism.

The loudspeaker shall comply with the following safety standards; CE.

The loudspeaker shall meet the following performance specifications: On-axis system frequency range shall be 55 Hz to 20 kHz (-10 dB). The broadband sensitivity shall be 88 dB (2.83 V at 1m) SPL in full-space environment with recommended high-pass protection. The long-term power handling rating shall be 150W as defined in EIA-426B. The maximum continuous output shall be 110 dB SPL and the maximum peak output shall be 116 dB SPL. The nominal coverage pattern shall be 110 degrees horizontal, and 90 degrees vertical. The transformer shall have power taps 60W, 30W, 15W, 7.5W (3.8W 70V), plus an 8-ohm bypass, selectable using a slide switch on the rear of the enclosure. The loudspeaker Euroblock input connections shall allow for direct connection to 70-volt, 100-volt, or low-impedance amplifiers.

The loudspeaker outer dimensions shall be 13.9" x 7.73" x 8.17" (353.1mm x 196.3mm x 207.5mm) and the unit net weight shall be 13.0 lbs (5.9kg)

The warranty shall be 5 years. The loudspeaker shall be the AtlasIED AS-6T surface mounted loudspeaker.